

Dr. Miroslav Begovic ◀

Download
Presentation ▶



Harmonic and Reactive Power Compensation –
Improving the Efficiency and Resiliency of the
Distribution Network to Cope with Increased
Penetration of Distributed Energy Resources including
Energy Efficient Appliances, Photovoltaic Systems,
Electric Vehicles

TECHNICAL SESSION 4

SREDS19 · DOHA, QATAR · DEC. 2, 2019



About the Speaker

- PhDEE '89 Virginia Tech (Synchrophasors)
- Faculty Member and Chair of Electric Energy Research at School of ECE, Georgia Institute of Technology, 1989-2015
- Co-Designer of the Largest Roof Mounted PV System in the World, 1996 Olympic Village, Atlanta
- IEEE Power and Energy Society Governing Board, 2010-2017
- IEEE Power and Energy Society President and Chair of the PES Governing Board, 2014-2015
- ECE Department Head and Professor, Texas A&M University, since 2015



PV System Proliferation Issues

PV Module Efficiencies

- The record lab cell efficiency is 26.7% for mono-crystalline and 22.3% for multi-crystalline silicon wafer-based technology. The highest lab efficiency in thin film technology is 23.4% for CIGS and 21.0% for CdTe solar cells.
- In the last 10 years, the efficiency of average commercial wafer-based silicon modules increased from about 12% to 17% (Super-mono 21%). At the same time, CdTe module efficiency increased from 9% to 18%.
- In the laboratory, best performing modules are based on mono-crystalline silicon with 24.4% efficiency. Record efficiencies demonstrate the potential for further efficiency increases at the production level.
- In the laboratory, high concentration multi-junction solar cells achieve an efficiency of up to 47.1% today. With concentrator technology, module efficiencies of up to 38.9% have been reached.

PV Inverters

- Inverter efficiency for state-of-the art brand products **98%** and higher.
- The market share of string inverters is estimated to be **52%**. These inverters are mostly used in residential, small and medium commercial applications in PV systems up to **150 kWp**. The market share of central inverters, with applications mostly in large commercial and utility-scale systems, is about **44%**.
A small proportion of the market (about **1%**) belongs to micro-inverters (used on the module level). It is estimated that **3 GWp** of DC / DC converters, also called “power optimizers”, have been installed in **2017**.
- The specific net retail price of all inverters in Germany is about **12 €-cents /Wp**. Central inverters tend to be cheaper than string inverters.
- Trends: Digitalisation, Repowering, new features for grid stabilization and optimization of self-consumption; storage; utilization of innovative semiconductors (SiC or GaN) which allow very high efficiencies and compact designs, **1500 V** maximum DC string voltage.

Energy Payback Time

- Material usage for silicon cells has been reduced significantly during the last 13 years from around 16 g/Wp to about 4 g/Wp due to increased efficiencies, thinner wafers and wires as well as larger ingots.
- The Energy Payback Time of PV systems is dependent on the geographical location: PV systems in Northern Europe need around 2.5 years to balance the input energy, while PV systems in the South equal their energy input after 1.5 years and less, depending on the technology installed.
- A PV system located in Sicily with multi-Si modules has an Energy Payback Time of around one year. Assuming 20 years lifespan, this kind of system can produce twenty times the energy needed to produce it.
- The Energy Payback Time for CPV-Systems in Southern Europe is less than 1 year.

Energy Payback Time

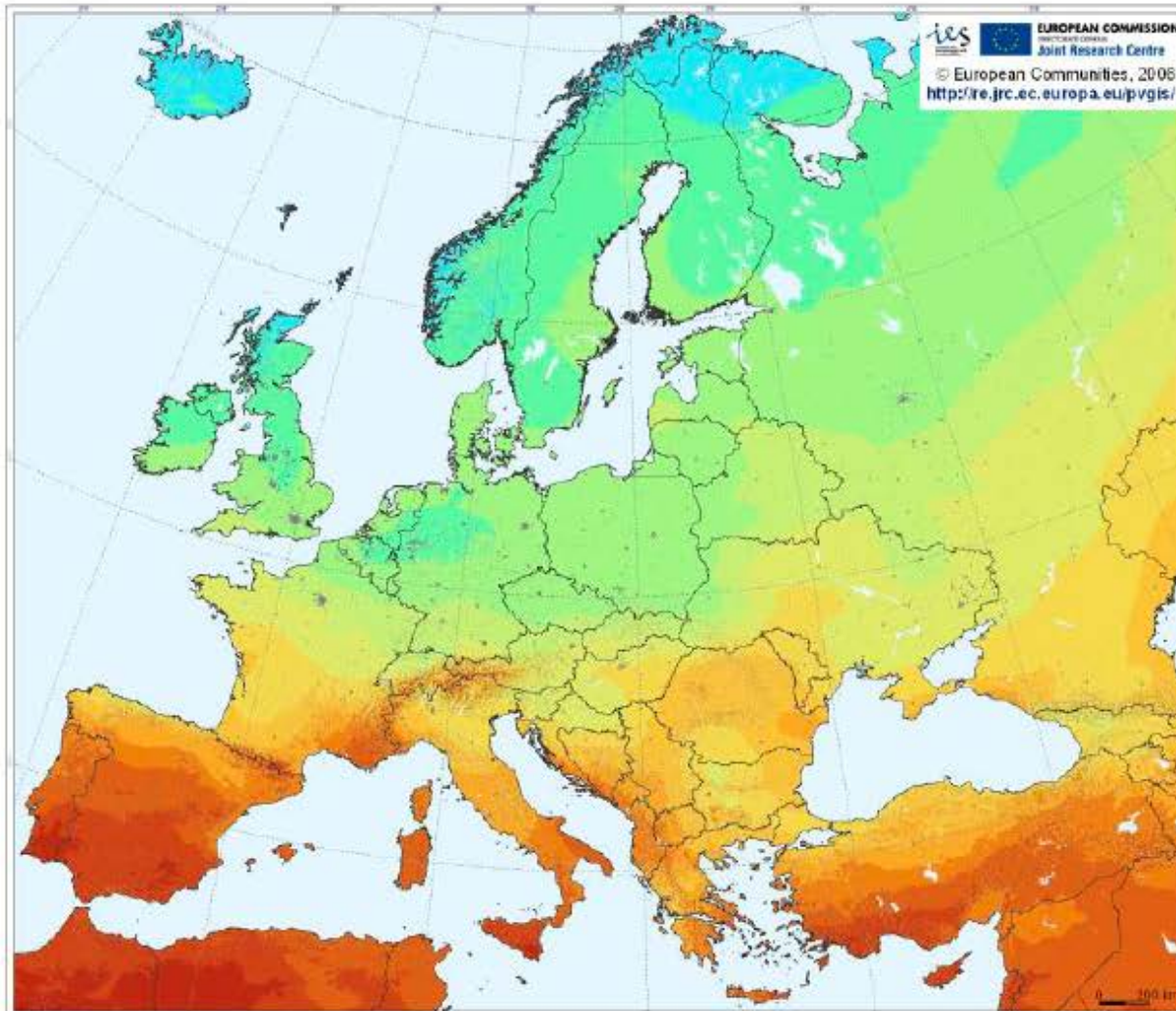

Irradiation (kWh/m²/a) EPBT

<600

800

1000

1200

1400

1600

1800

2000

>2200

2.1 years

1.2 years

Data: M.J. de Wild-Scholten 2013. Image: JRC European Commission. Graph: PSE 2014 (Modified scale with updated data from PSE and FraunhoferISE)

Total Global Solar PV Additions 2008-2018

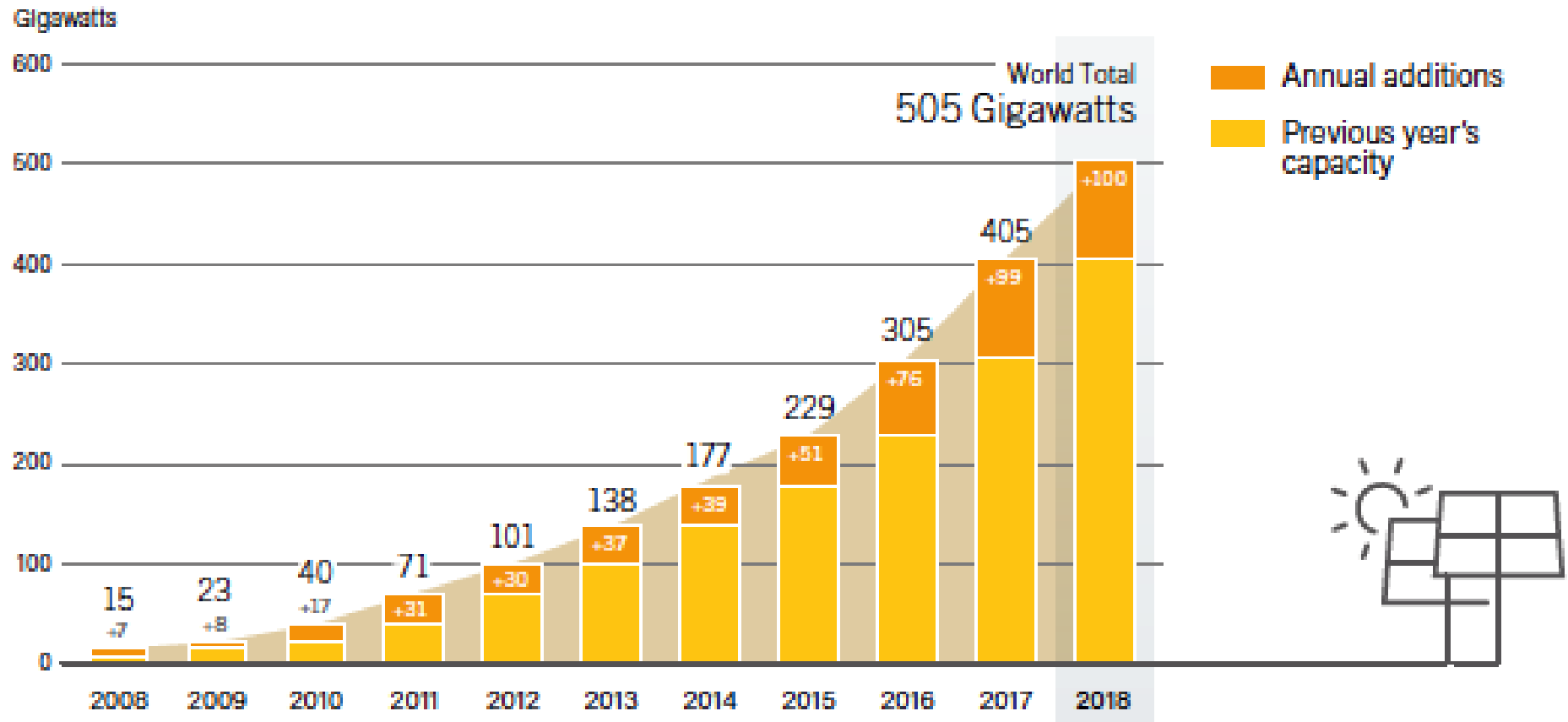

Note: Data are provided in direct current (DC).
Totals may not add up due to rounding.

Source: Becquerel Institute and IEA PVPS.
See endnote 2 for this section.

Total PV Additions by Country - 2018

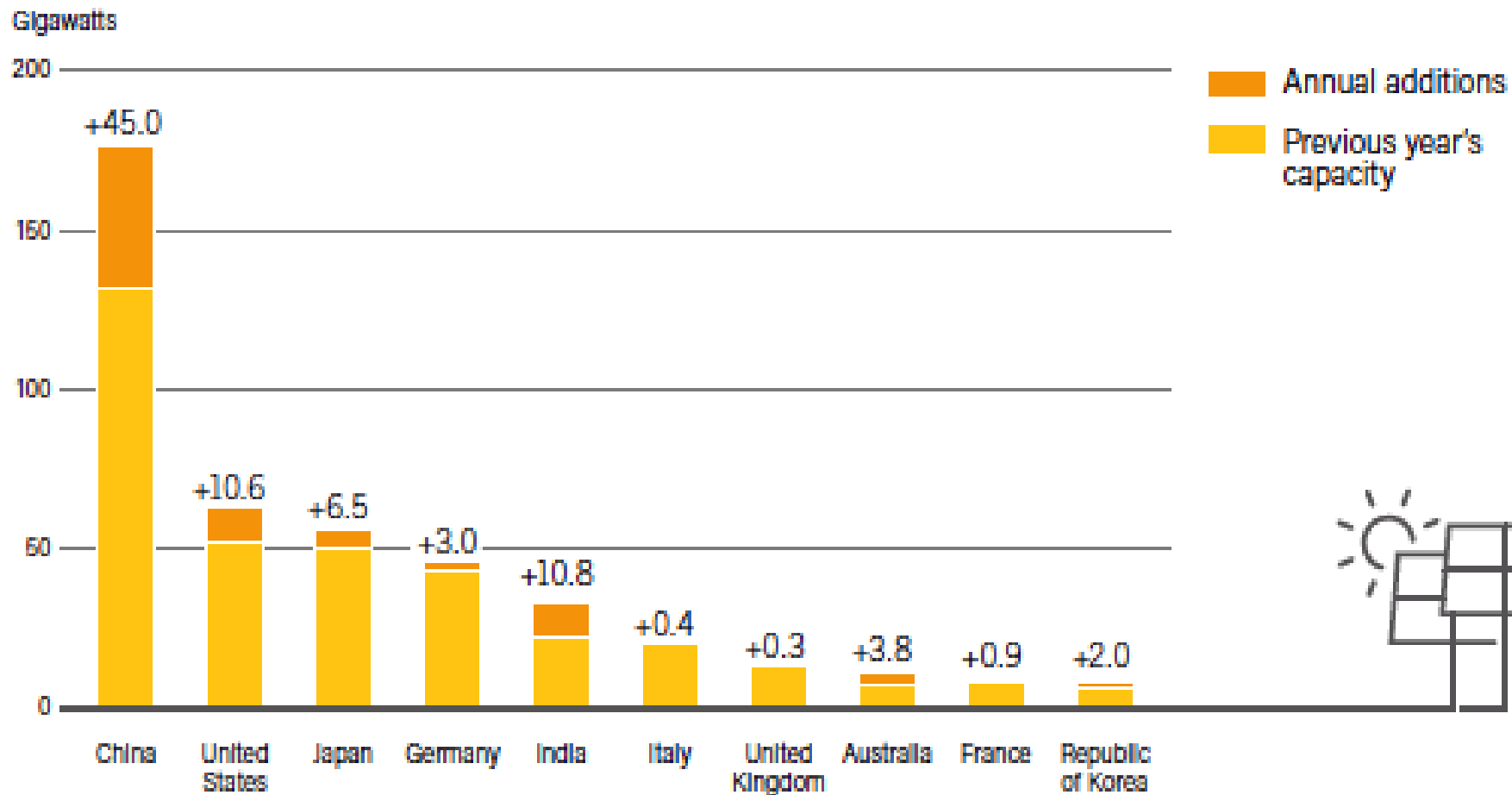

Note: Data are provided in direct current (DC).
Data for India are highly uncertain.

Source: See endnote 23 for this section.

Regional Dependency of LCOE for Solar PV

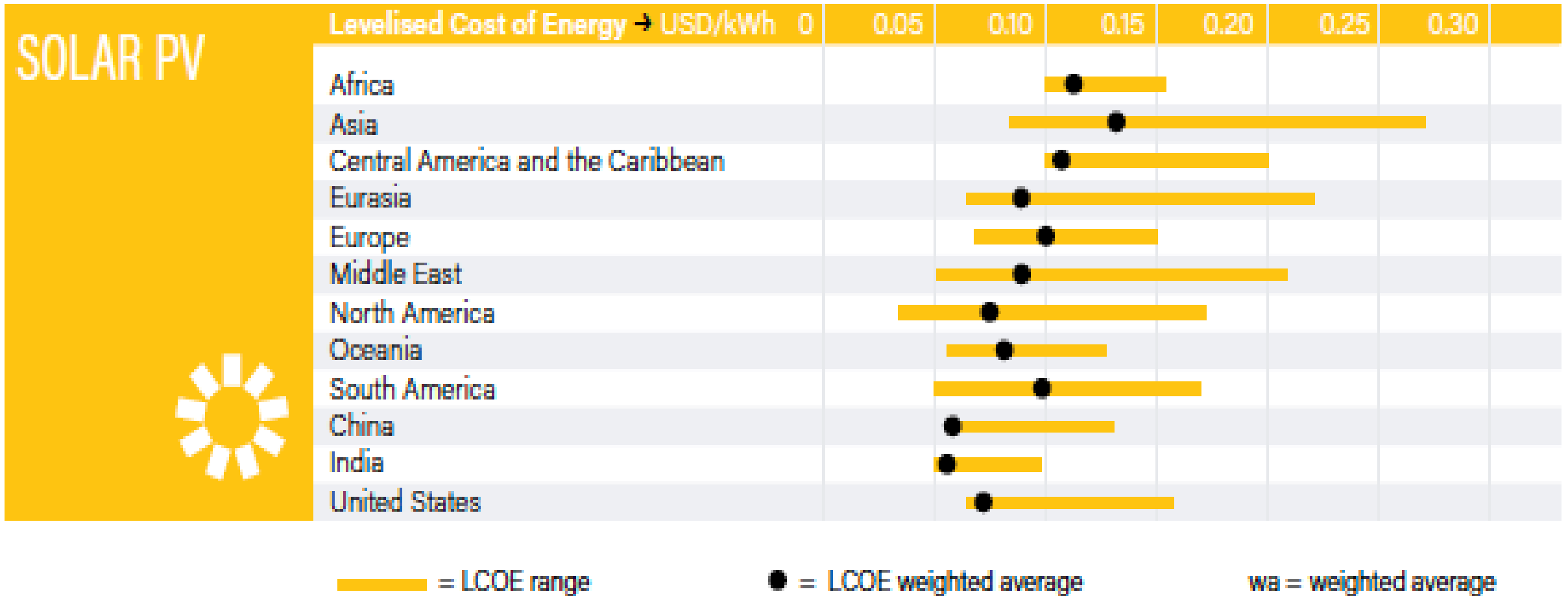

Projections for Solar PV Market

Global PV inverter revenues (\$M)

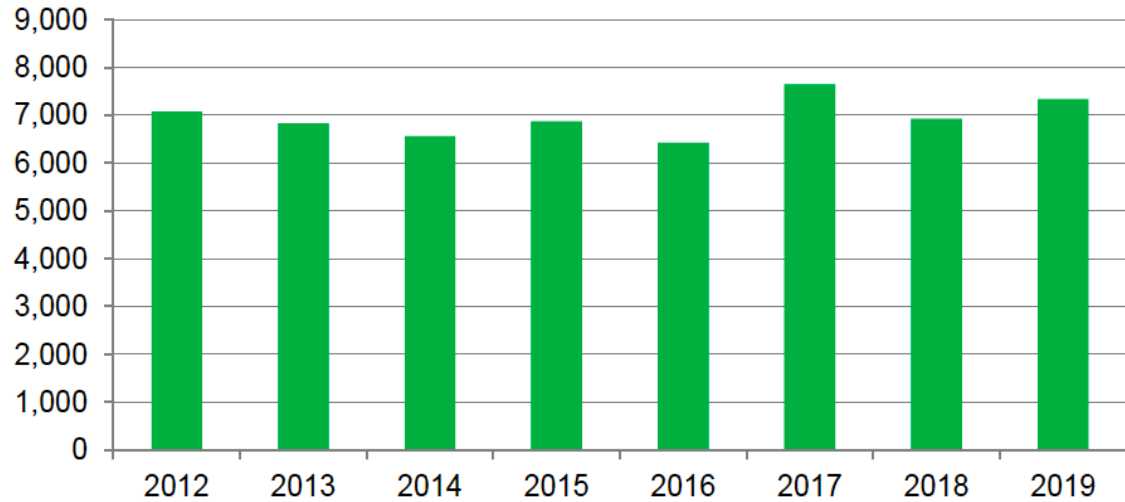

Source: IHS Markit

© 2019 IHS Markit



Average crystalline PV module efficiency (%)

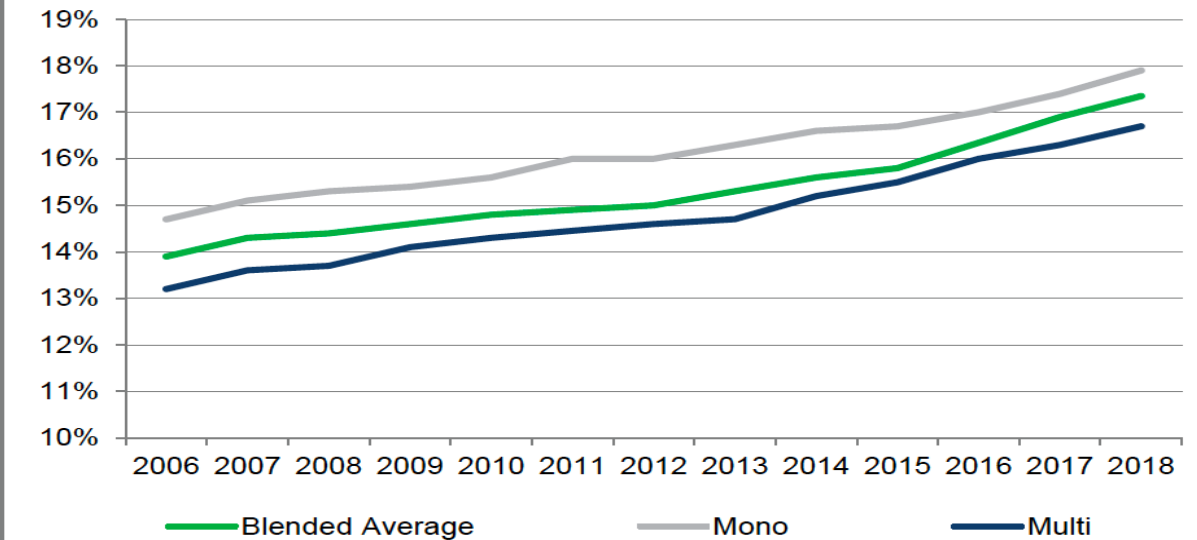

Source: IHS Markit

© 2019 IHS Markit



Predictions on Solar PV

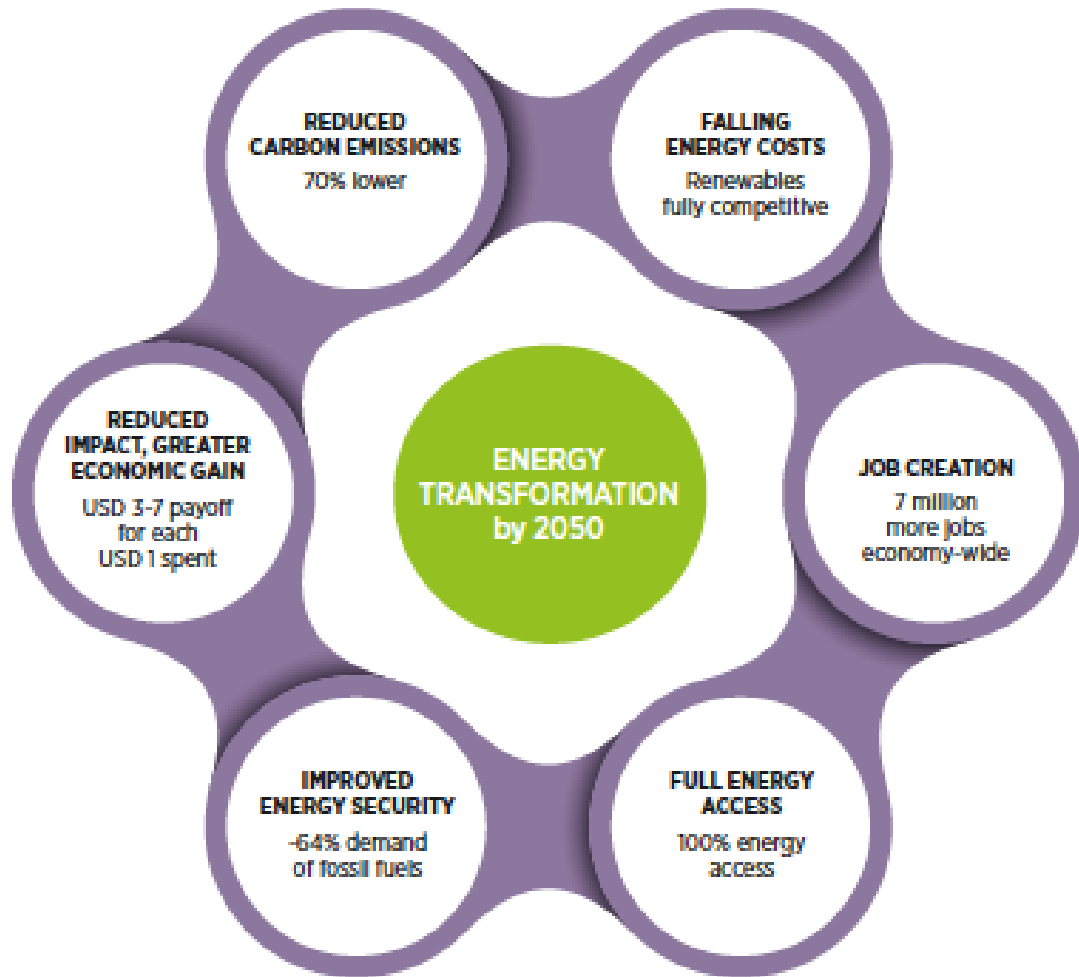

2010 2018 2030 2050 ON/OFF TRACK

TOTAL INSTALLATION COST



LEVELISED COST OF ELECTRICITY (LCOE)

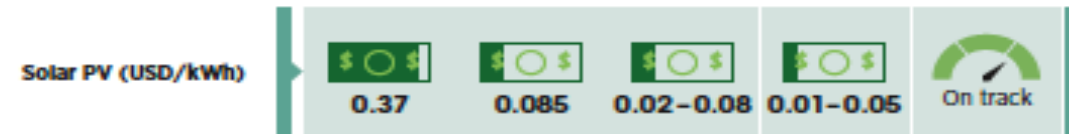

AVERAGE ANNUAL INVESTMENT



EMPLOYMENT

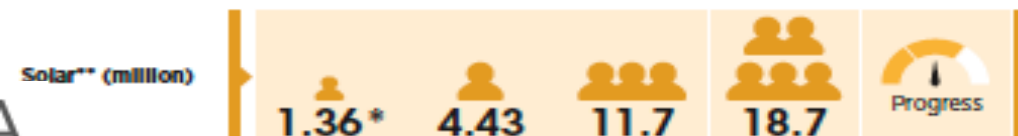

Sixfold Growth of Solar PV by 2030

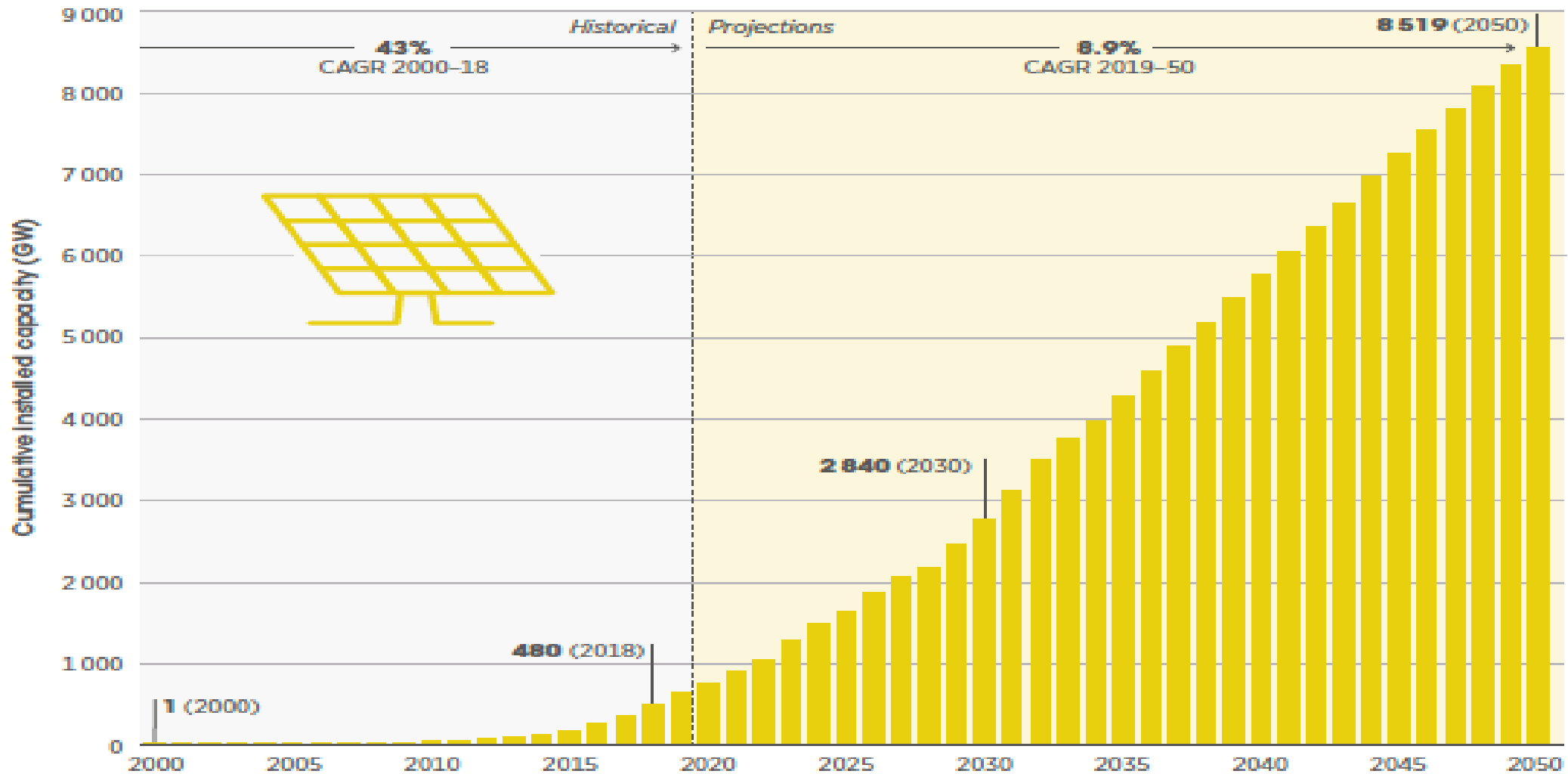

Sources: Historical values based on IRENA's renewable energy statistics (IRENA, 2019c) and future projections based on IRENA's analysis (2019a).

Barriers for Further Massive Deployment

TECHNOLOGICAL BARRIERS

- Grid-connection and integration challenges
- Grid-flexibility challenges
- Lack of capacity/skilled labour
- Architectural and space barriers

MARKET AND ECONOMIC BARRIERS

- Long payback periods
- Carbon emissions and local air pollutants are not priced or fully priced
- Low wholesale power prices in countries with low levels of irradiation

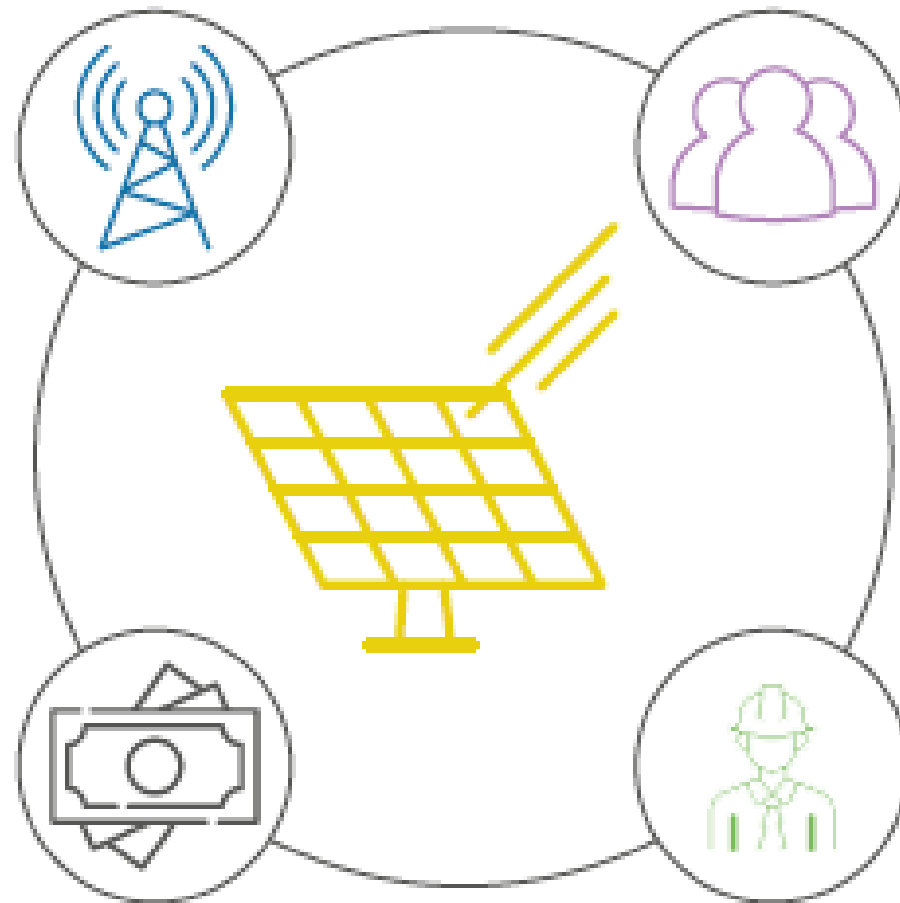

POLICY BARRIERS

- Complex/outdated regulatory framework
- Lack of long-term and stable policy targets and well-coordinated policy mix
- Lack of quality control measures
- Concerns about technology maturity and performance

REGULATORY, POLITICAL AND SOCIAL BARRIERS

- Lack of consumer information on performance, costs competitiveness and economics of solar PV
- Lack of relevant standards and quality control measures
- Lack of skilled professionals and experience

Materials in 1MW Solar PV Plant

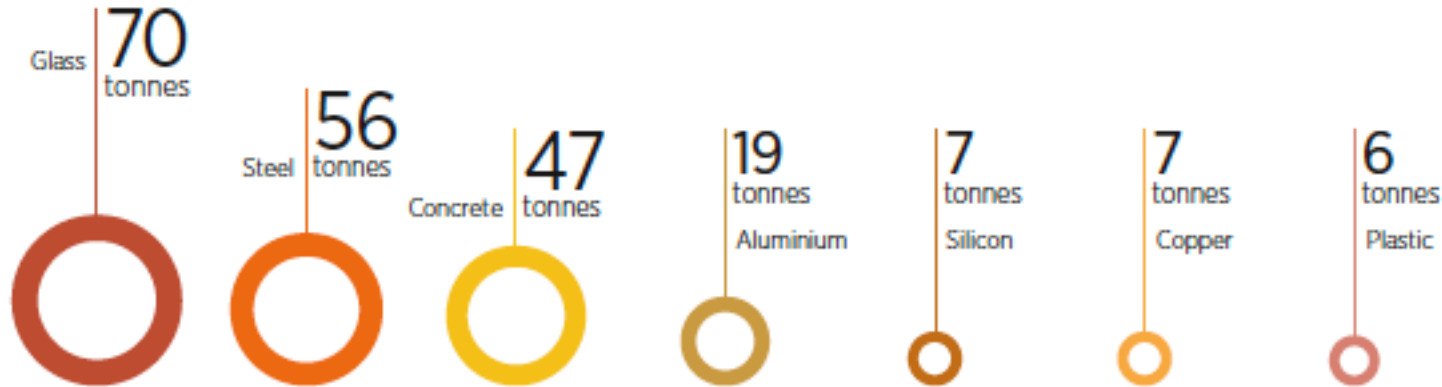

Source: IRENA (2017b).

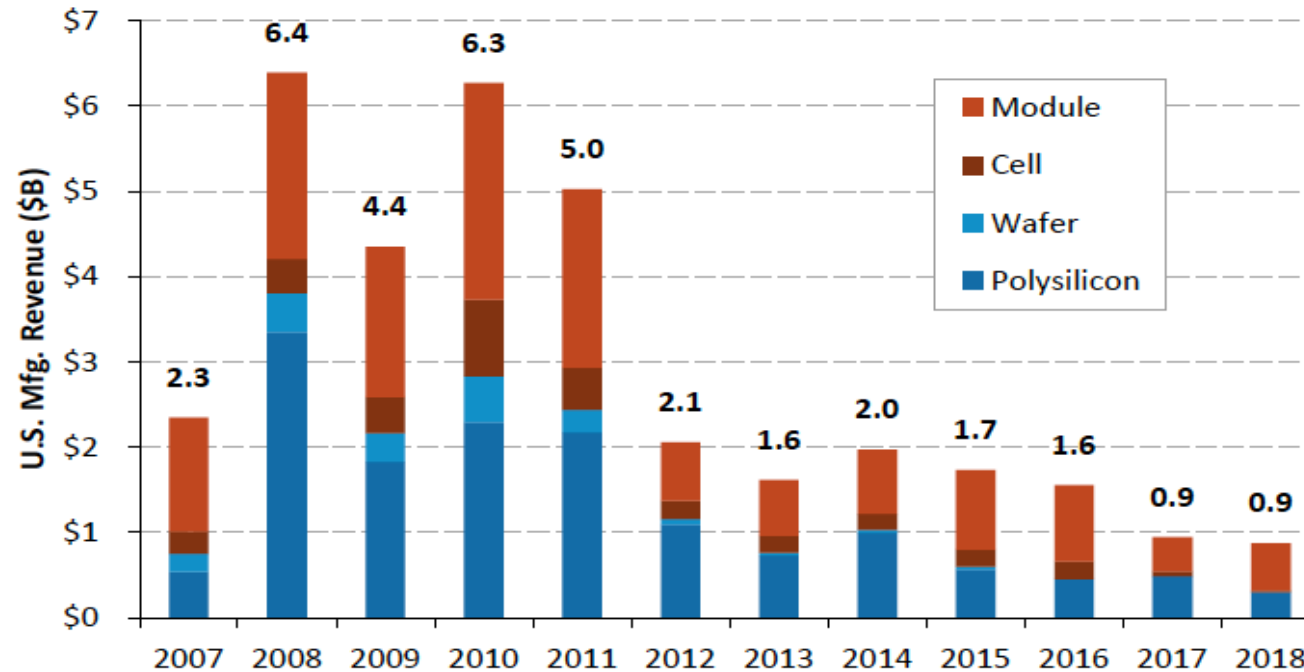

Resource Consumption for Material Production...

(Energy Required for Top 7 Materials: 1.5 TW – 10% of Global Energy)

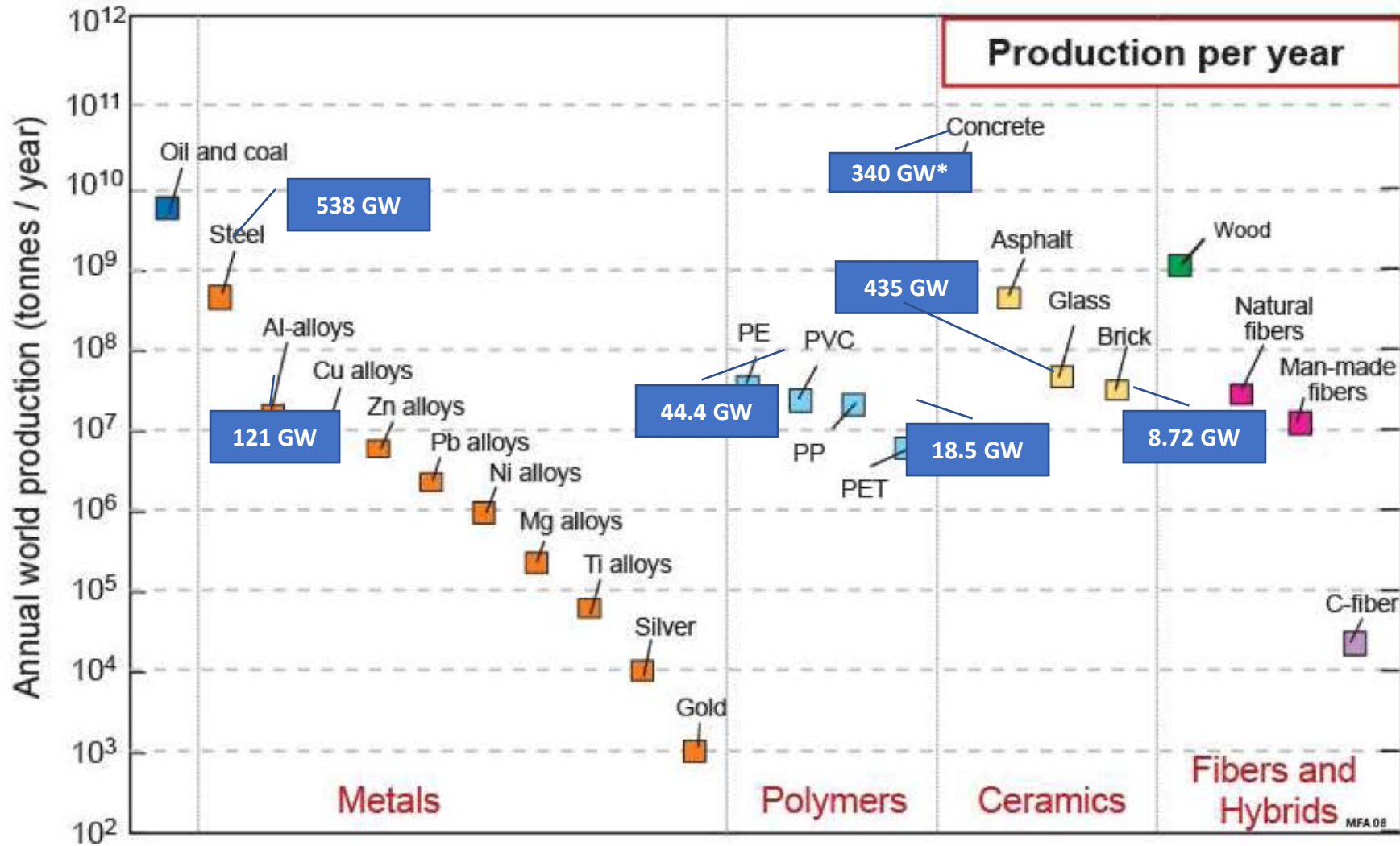

...but the resources (and energy) are finite!

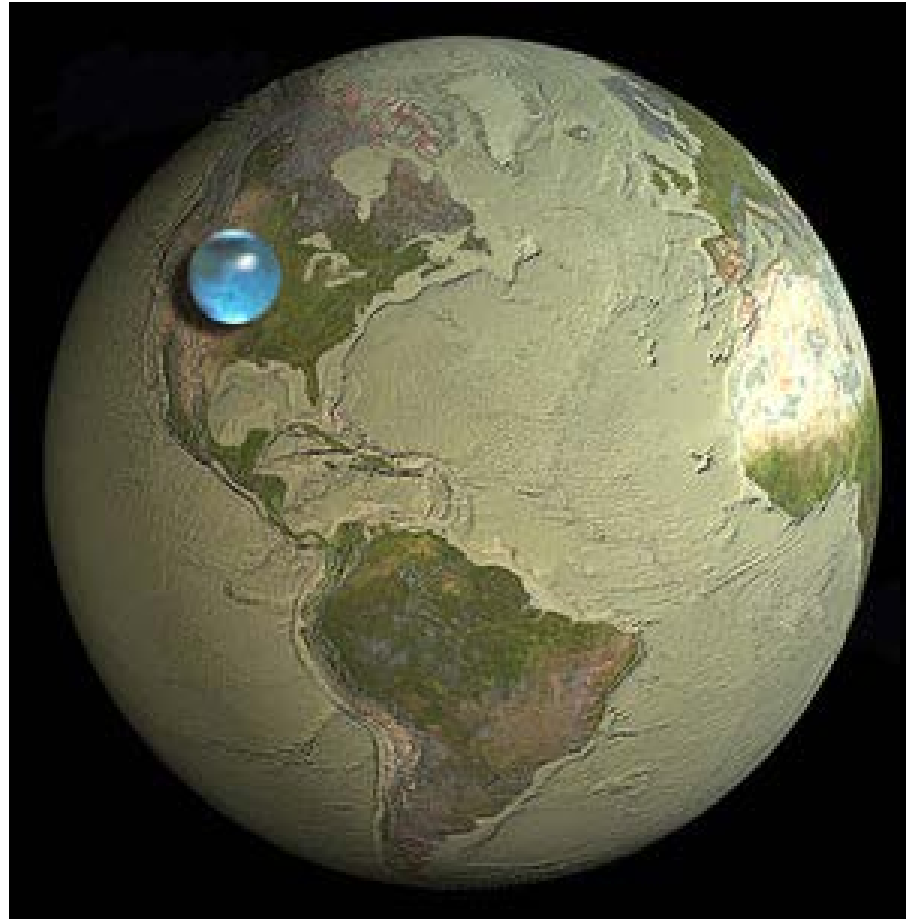

Energy Related Issues

- **Smart Cities –**
 - **80% of EUs GDP,**
 - **68% of population, 85% by 2050**
 - **70% of energy consumption,**
 - **75% OF GHG emissions**
 - **Microgrid Deployment, Virtual Power Plants**
 - **Multiple Interacting Infrastructures (electricity, fuels, heat, cooling, transport, water, waste, etc.)**
 - **Regulation and Policy Interventions**

Could PV electricity be cheaper than new nuclear ?

109 EUR/MWh

Hinkley Point - UK



80 EUR/MWh

Fraunhofer ISE – Central Germany –
Cheapest utility-scale



Why Solar Energy and Solar Cells?

- Model of LCOE [cents/kWh] VS Module cost and efficiency

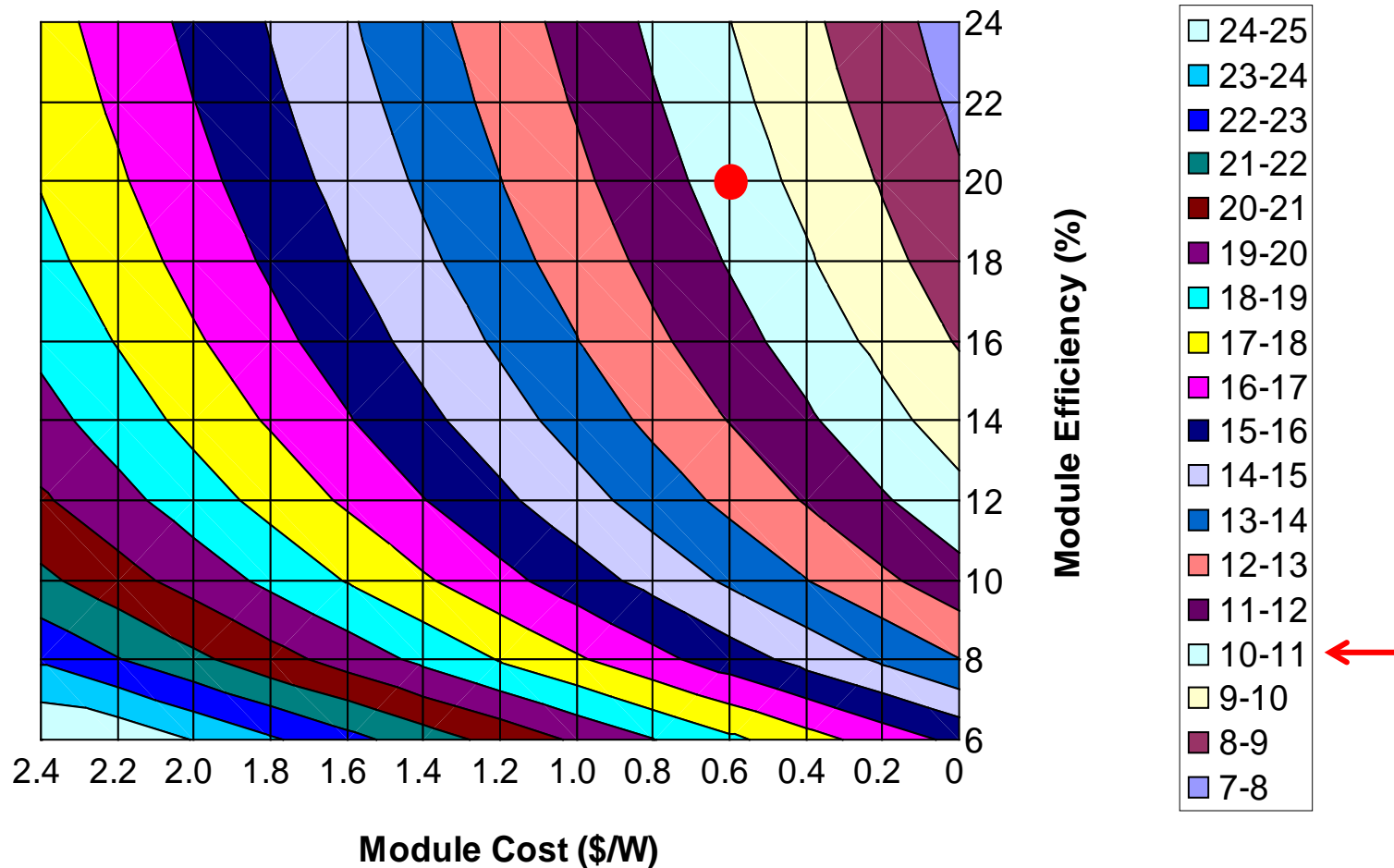

Assumption for chart preparation: 25 year lifetime, 20% derate, 7.69% WACC, No ITC, 50% debt fraction, 7% loan rate, and 5 year loan term

Projected Economies of Scale

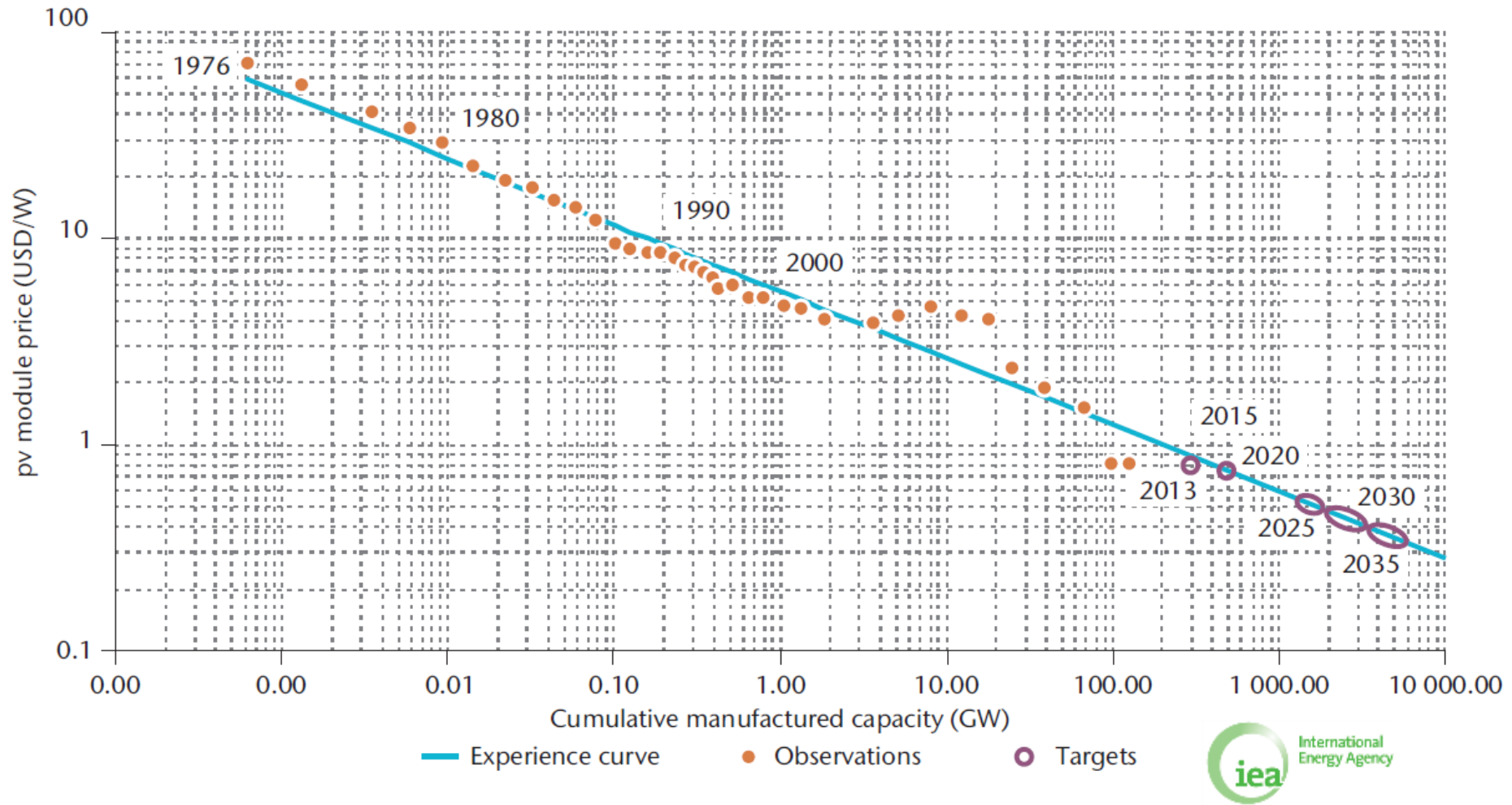

LCOE and Grid Parity Lines

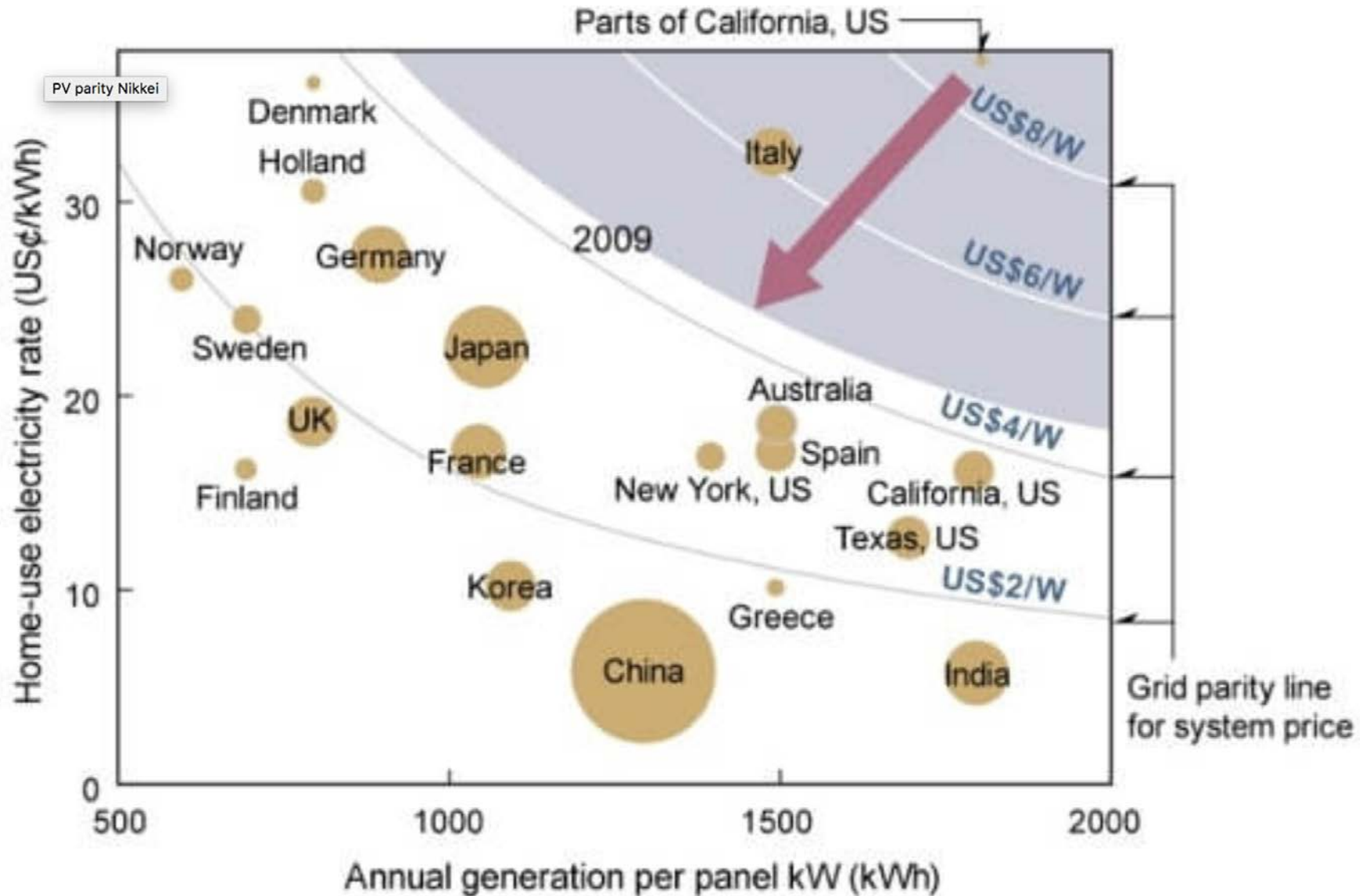

Projected LCOEs of PV and STE

USD/MWh		2013-15	2020	2030	2040	2050
Utility-scale PV	Mini	119	96	56	45	42
	Avg	177	133	81	68	54
	Maxi	318	250	139	109	97
Rooftop PV	Mini	135	108	63	51	45
	Avg	201	157	102	91	78
	Maxi	539	422	231	180	159
STE	Mini	146	116	86	69	64
	Avg	168	130	98	77	71
	Maxi	213	169	112	101	94

<i>CO₂ price (USD/tCO₂)</i>			46	115	152	160
---	--	--	----	-----	-----	-----

Note: all costs are calculated with 8% weighted average capital costs for new-built plants/systems

© OECD/IEA 2014

Hidden Costs of Renewables



DER Integration in Distribution Systems

Integrated Grid

Operational Excellence

System Performance

OpEx Management

Asset Optimization

Emissions Mgmt

Resilience

Impact Resistance

Contingency Management

Minimal Recovery

Nexus w/Gas, Water & Transp.

Adaptability

Accommodate Tech Innovation

Accommodate New Busn Models

Scalable System

Open & Interoperable

Cyber-physical Security

Threat Detection & Mitigation

Access Control & Data Protection

Device/System Integrity

Physical Security

Safety

Public Safety

Workforce Safety

Operational Risk Management

Fail Safe Modes

Issues with High Level Renewable

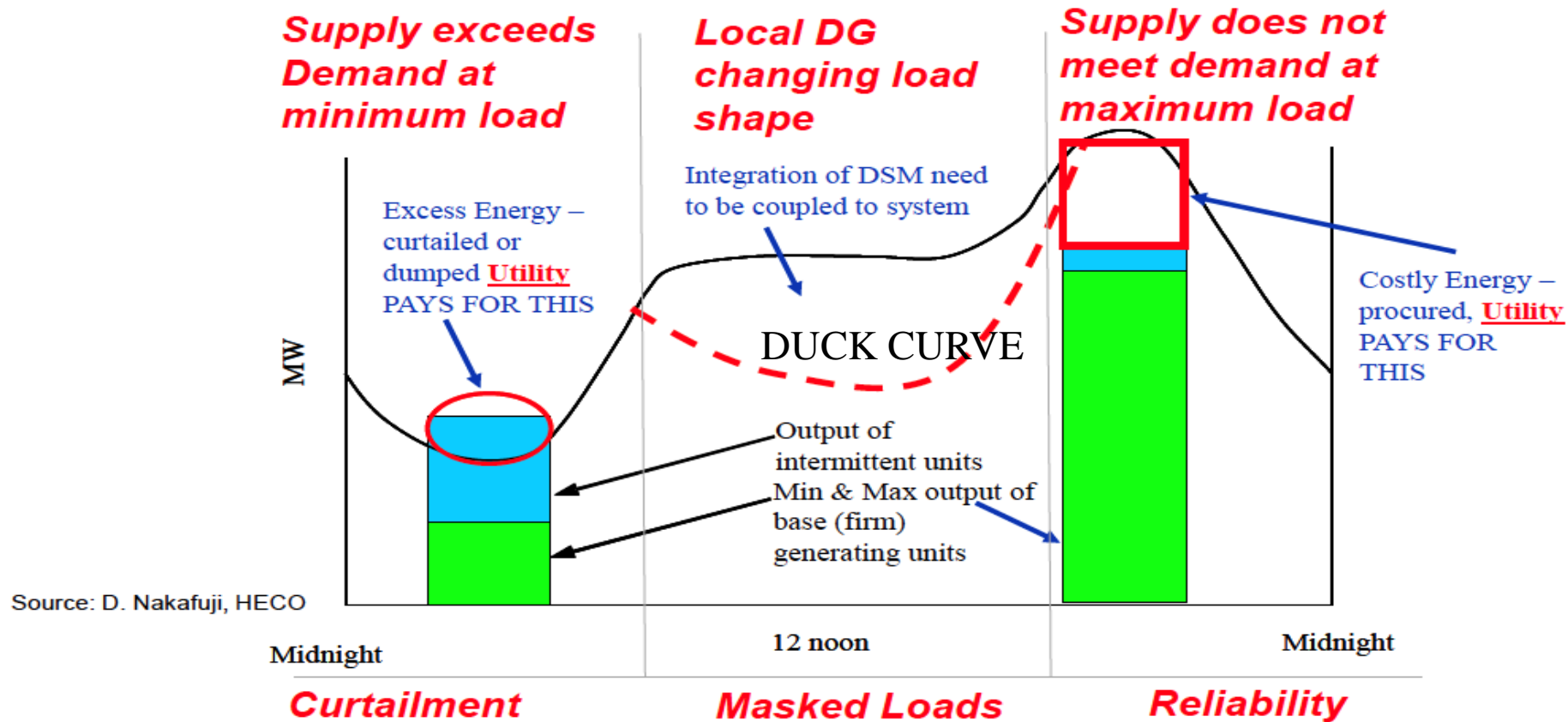

Impact of Solar PV

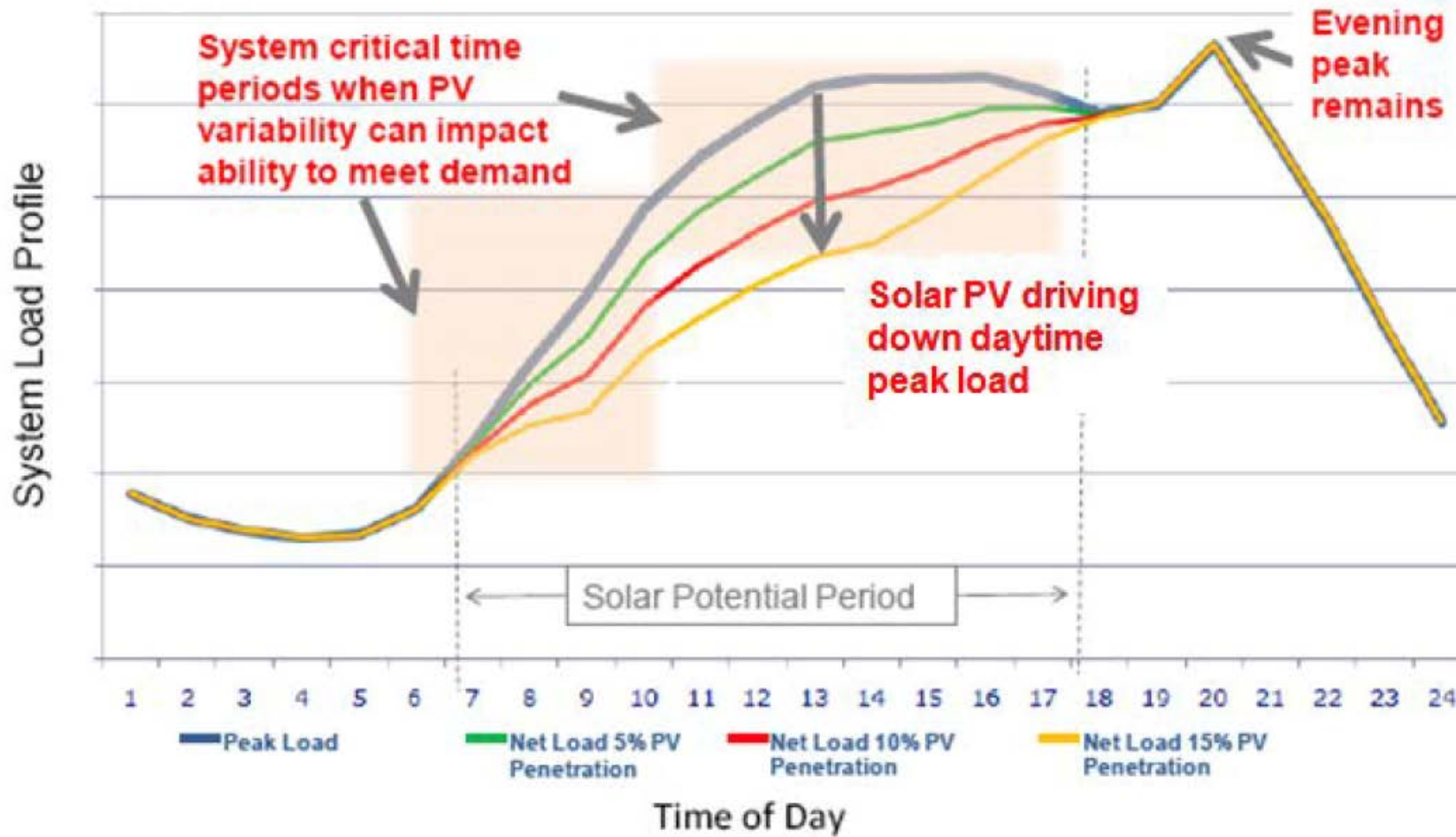

TEST BEDS

- The Springs community, located in Chandler, AZ, was first selected and used as a test b



SIMULATION: Microturbine & PV Arrays.

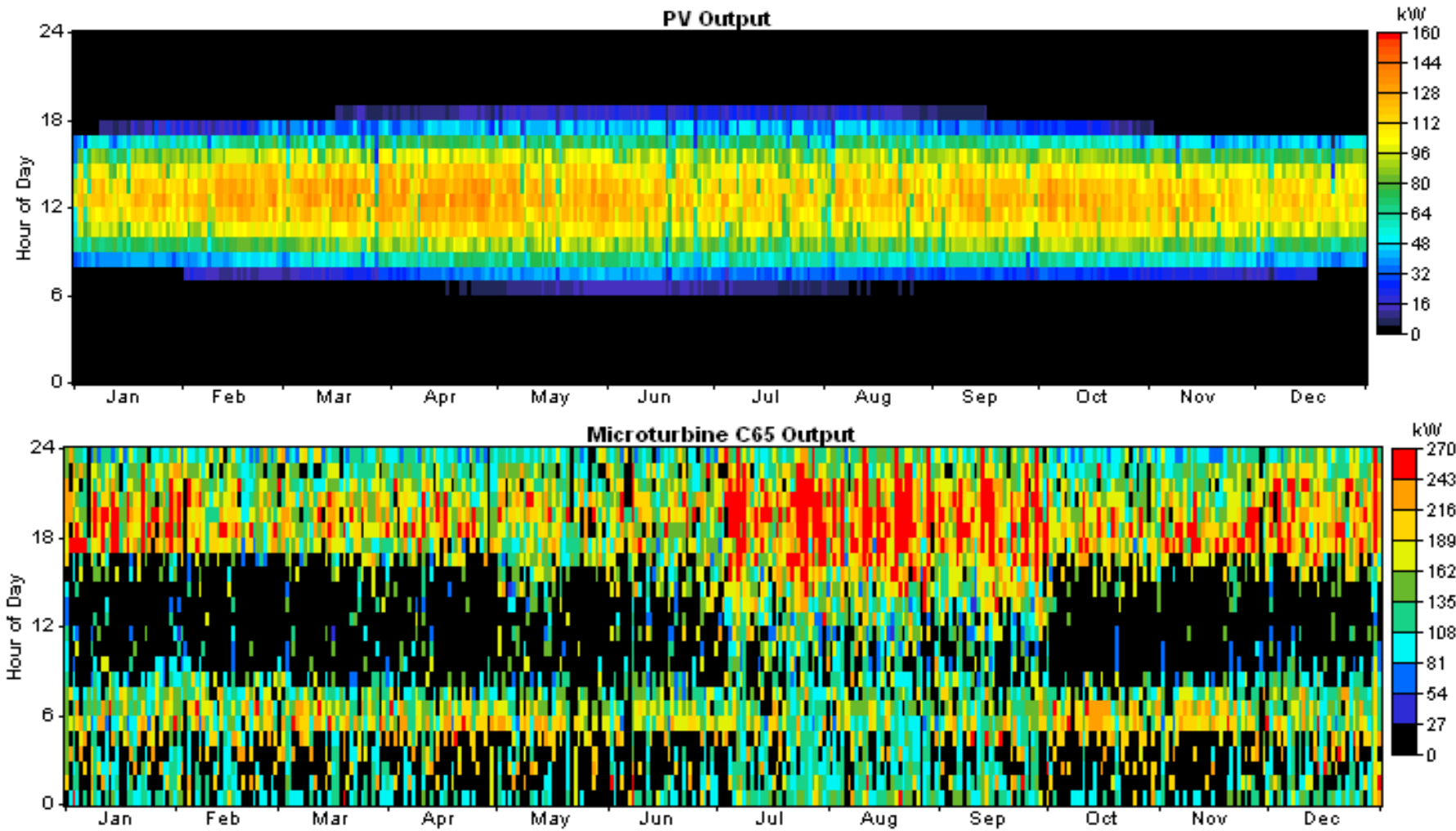

Conservative Voltage Reduction

PRINCIPLE OF VOLTAGE REDUCTION

- ADDITIONAL REACTIVE RESOURCES NEEDED FOR MAXIMUM BENEFIT
- LOW COST OF NEEDED RESOURCES
- POTENTIAL FOR MORE BENEFITS (LOSS REDUCTION, SOFT SHEDDING)

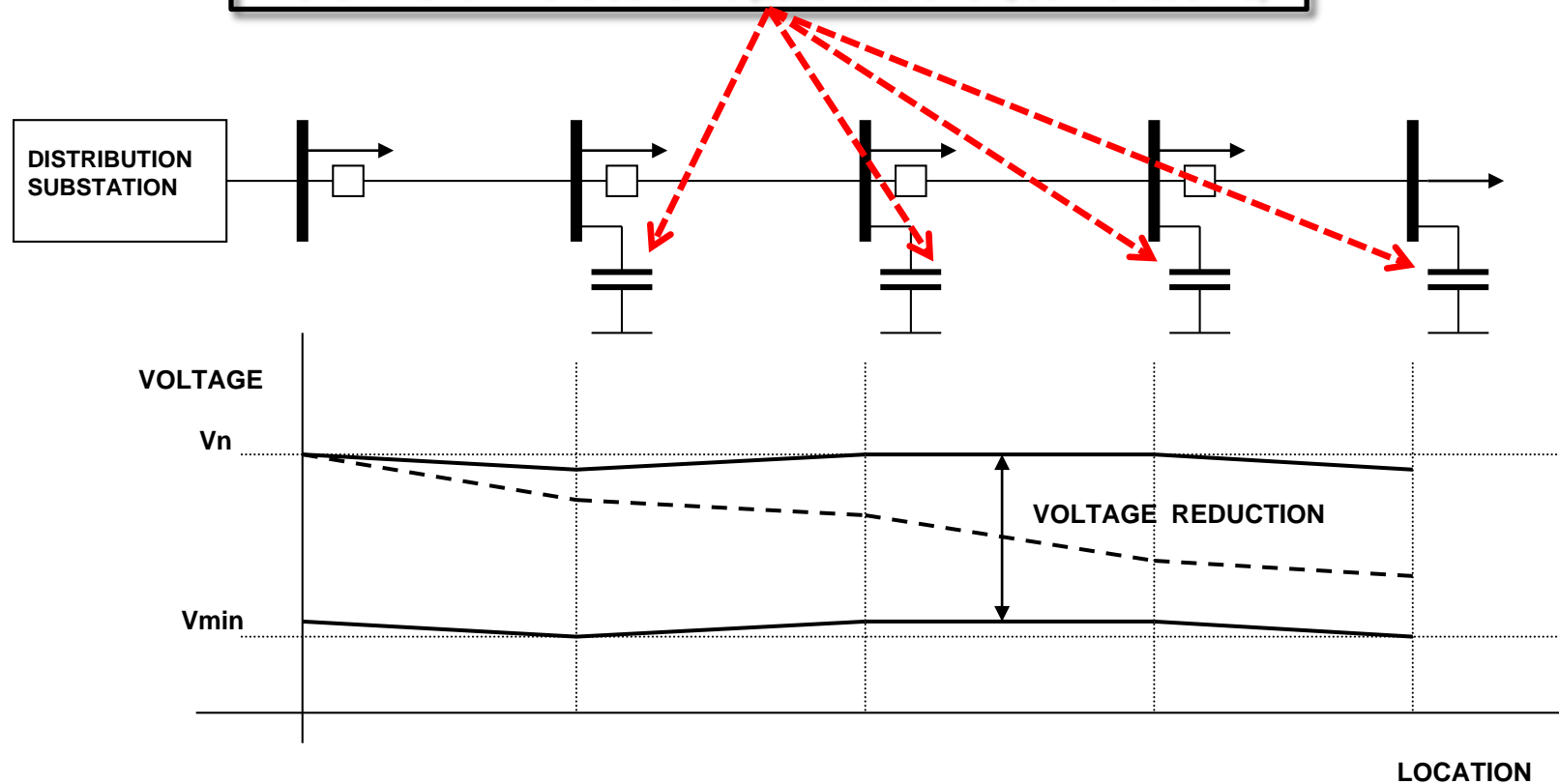

POTENTIAL PROBLEMS

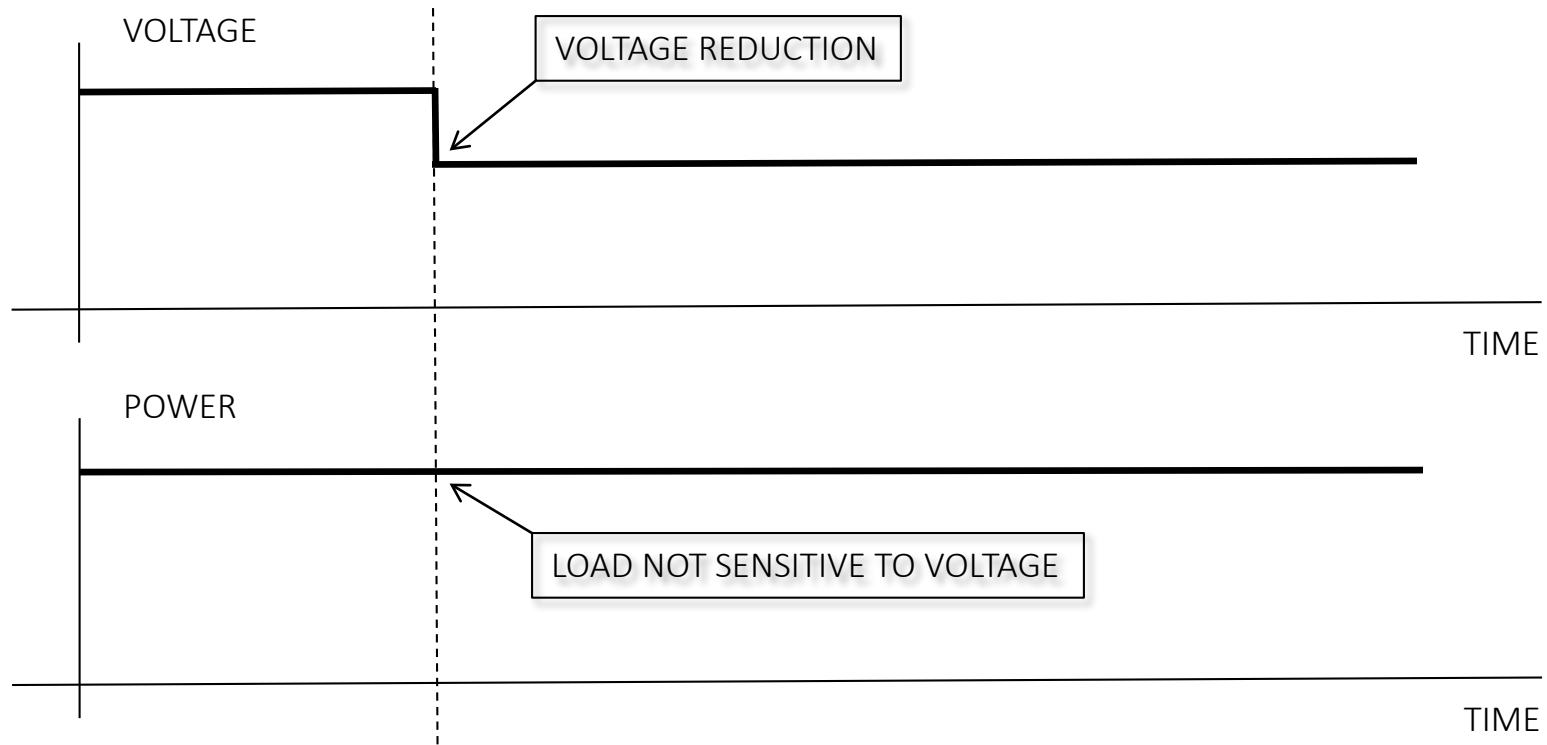

POTENTIAL PROBLEMS (CONT.)

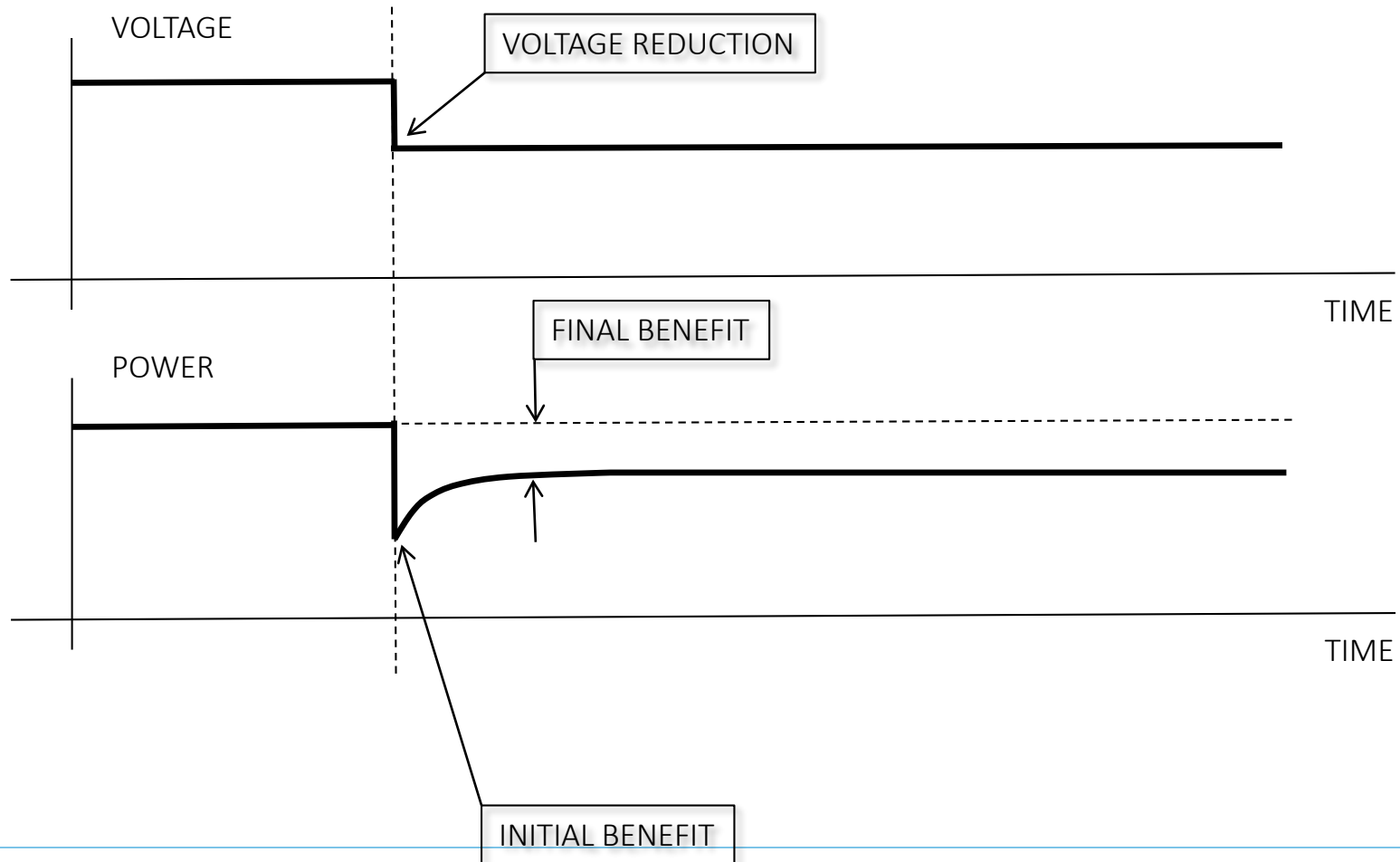

BENEFIT ASSESSMENT REQUIRES SPECIAL TOOLS

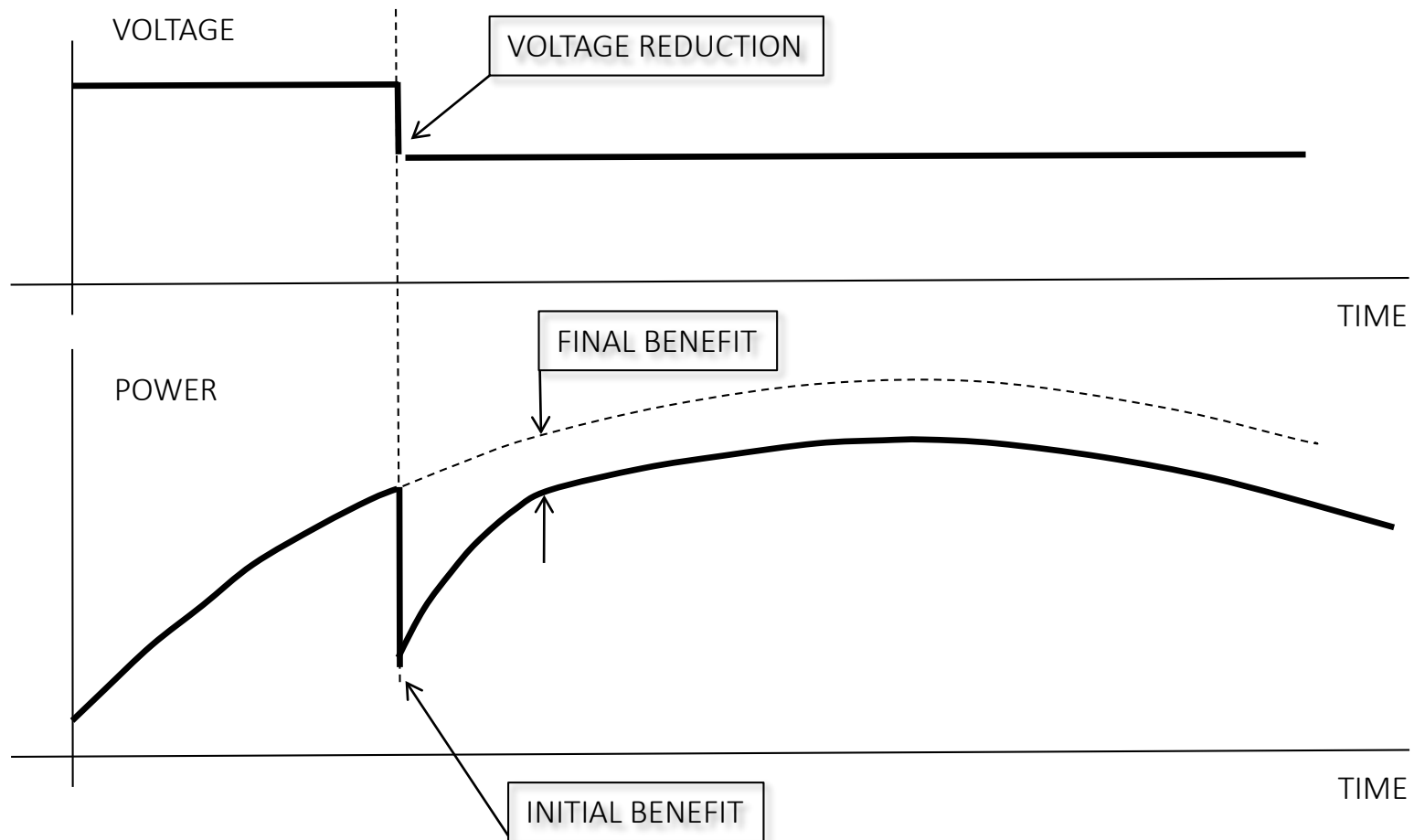

ANALYSIS OF BENEFITS

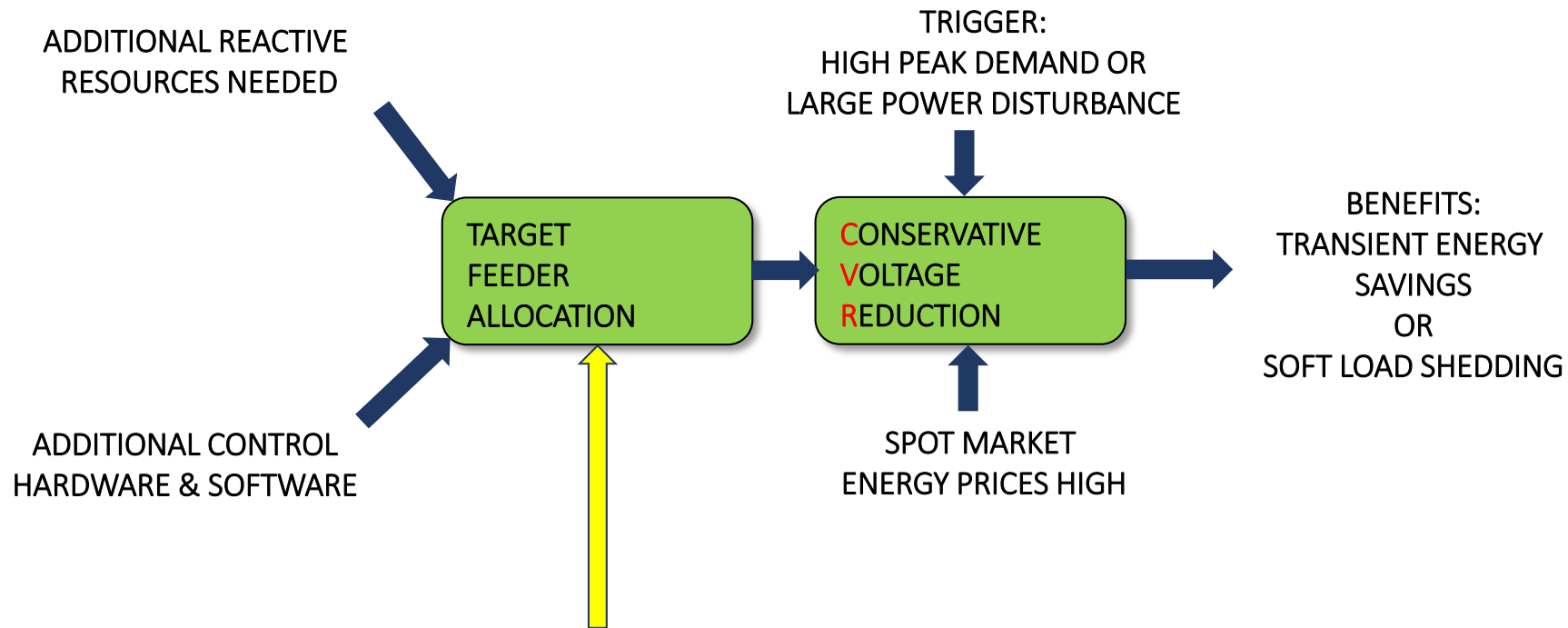

- ASSESSMENT OF NEEDED RESOURCES
- ALLOCATION OF THE BEST TARGET FEEDERS
- ASSESSMENT OF TRANSIENT AND FINAL BENEFITS
- COST BENEFIT ANALYSIS

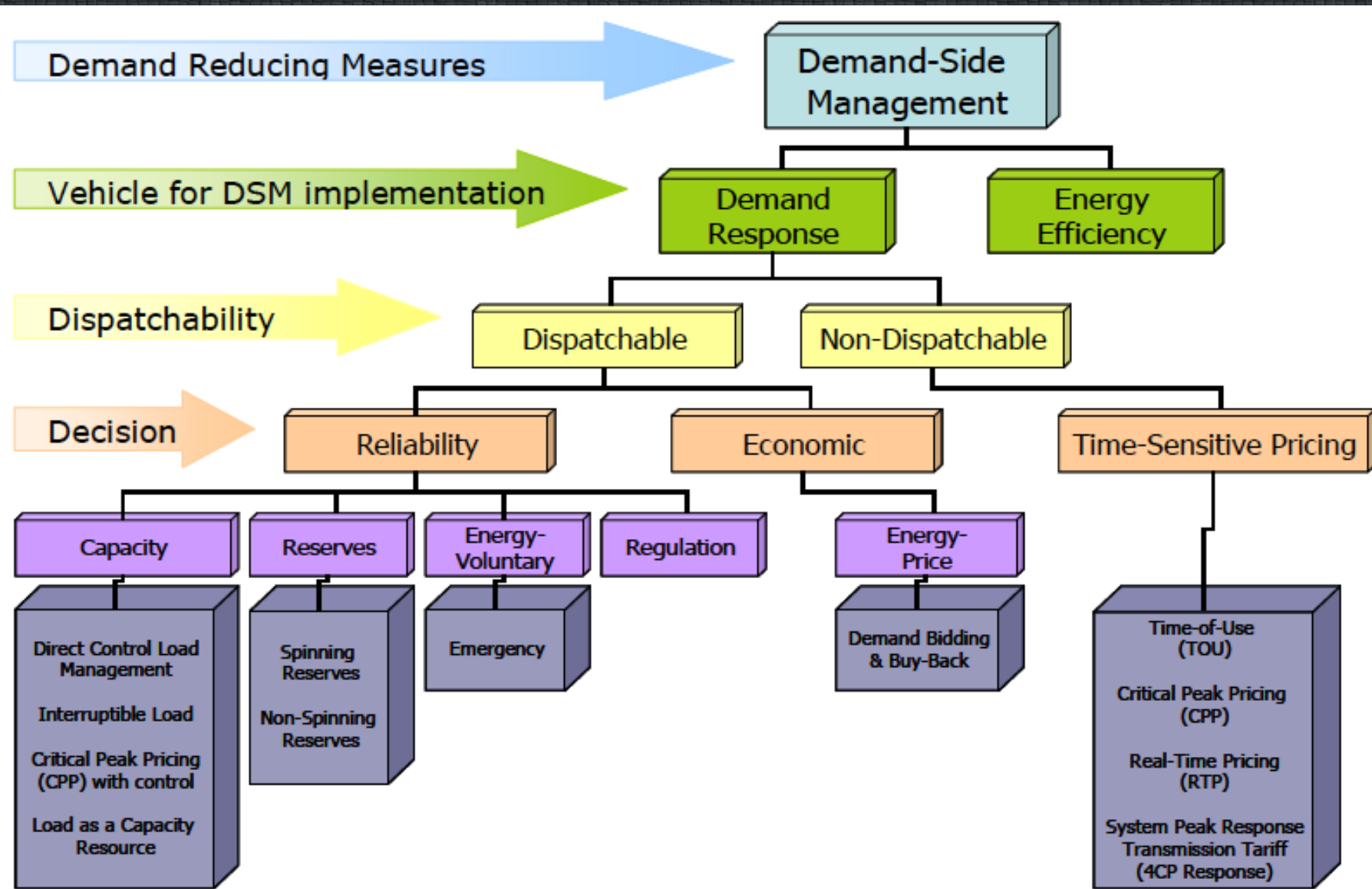

Volt/VAR Control with DER

Introduction to the problem

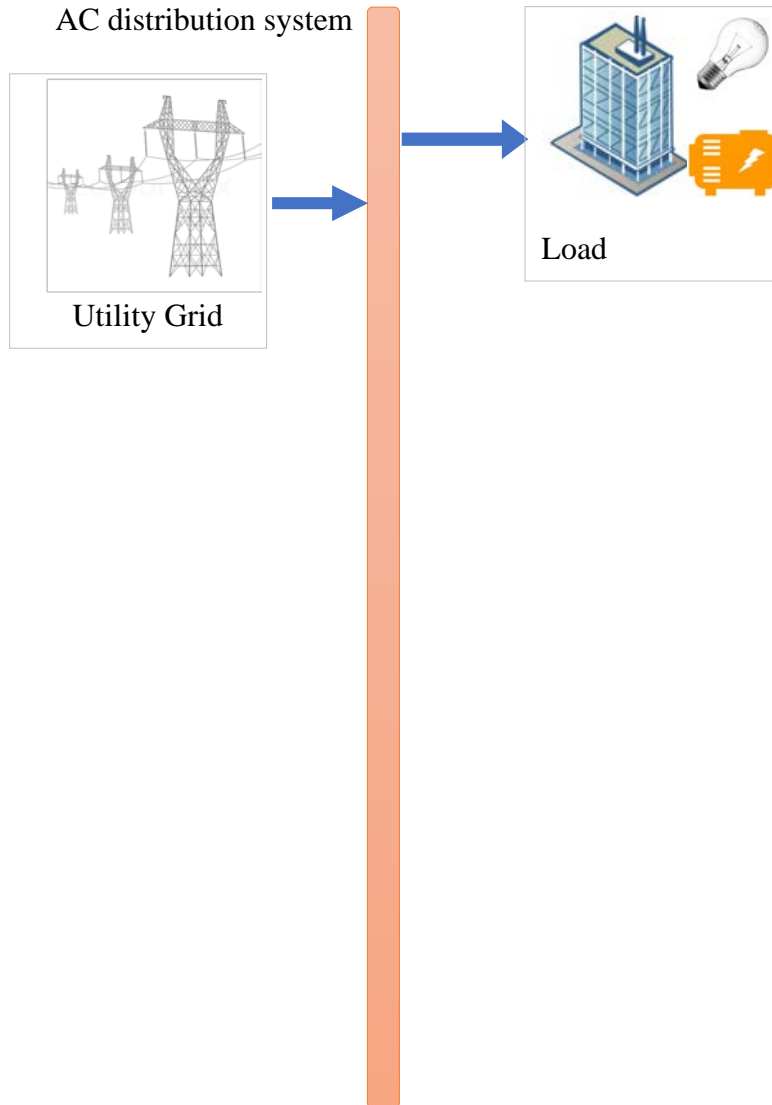

Century ago, the electrical power system envisioned by Tesla and developed by Westinghouse in the last century was based on unidirectional power flow from the central generation to the distributed load. Classical loads included resistive lights and motor and behaved linearly.

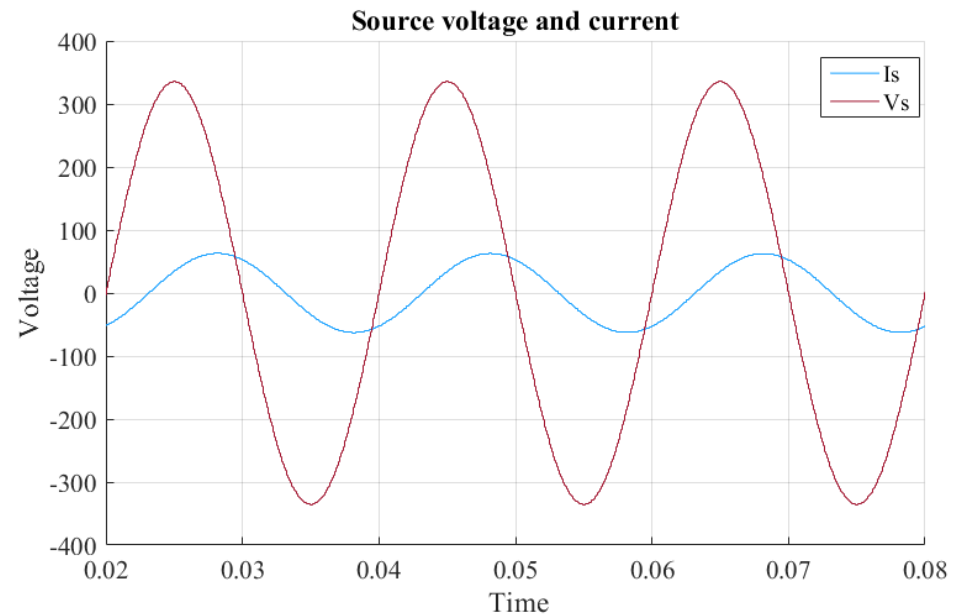

Introduction to the problem

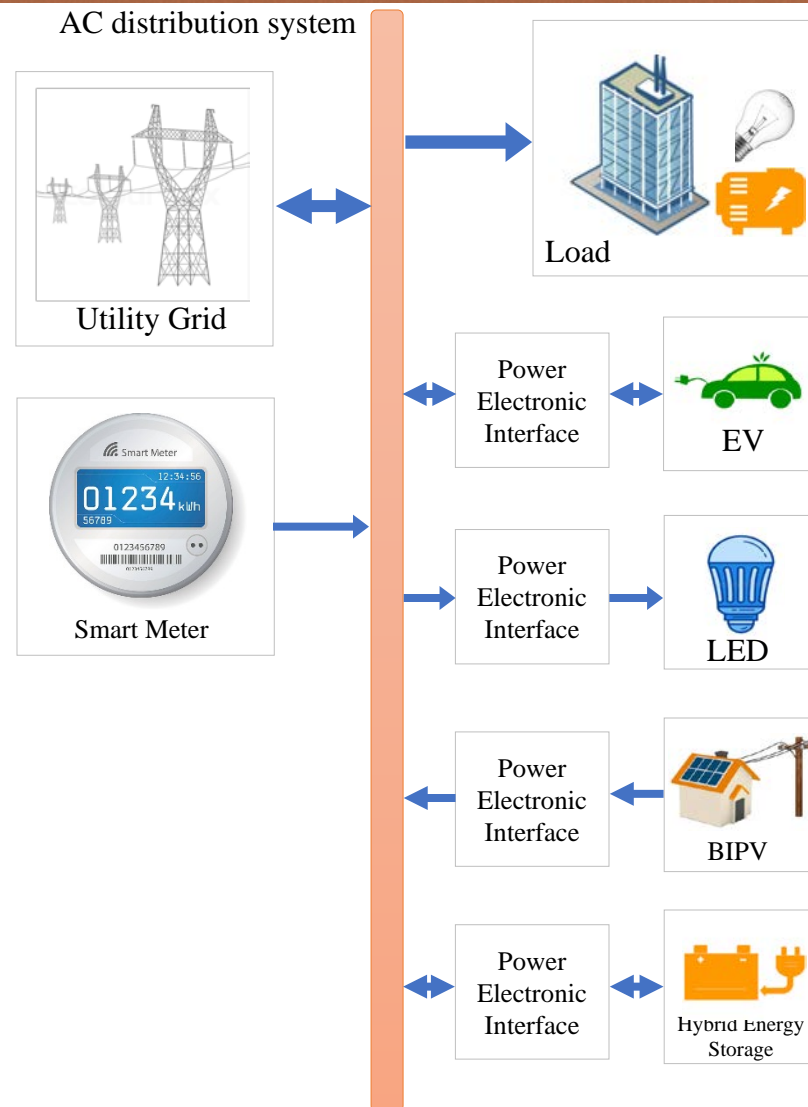

Today, distributed generation such as roof-top PV can cause the **voltage to change rapidly** and hence put excessive stress on the voltage control devices.

Modern loads also present non-linear impedances to the electrical system and hence draw **harmonic** and **reactive power**.

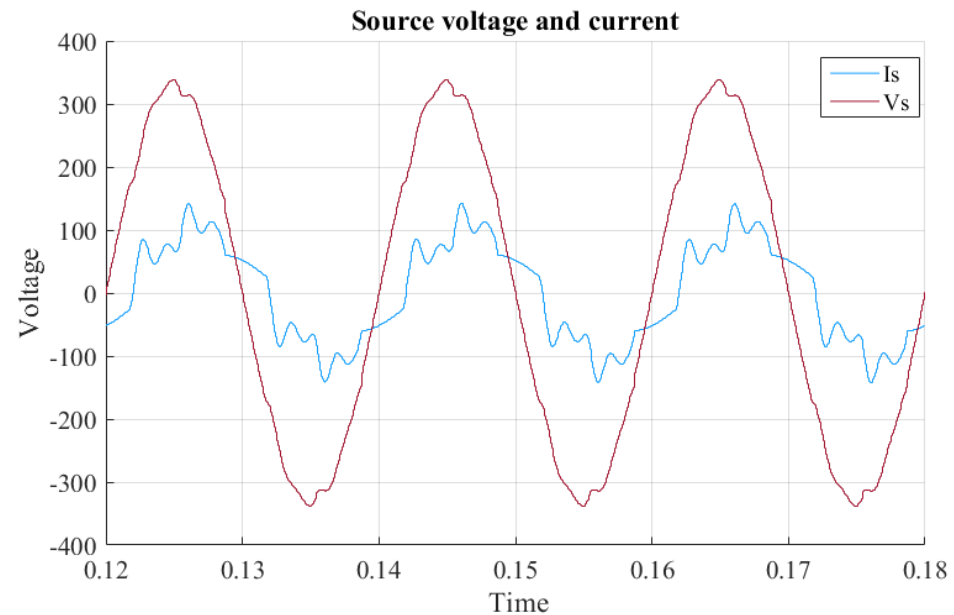

Introduction to the problem

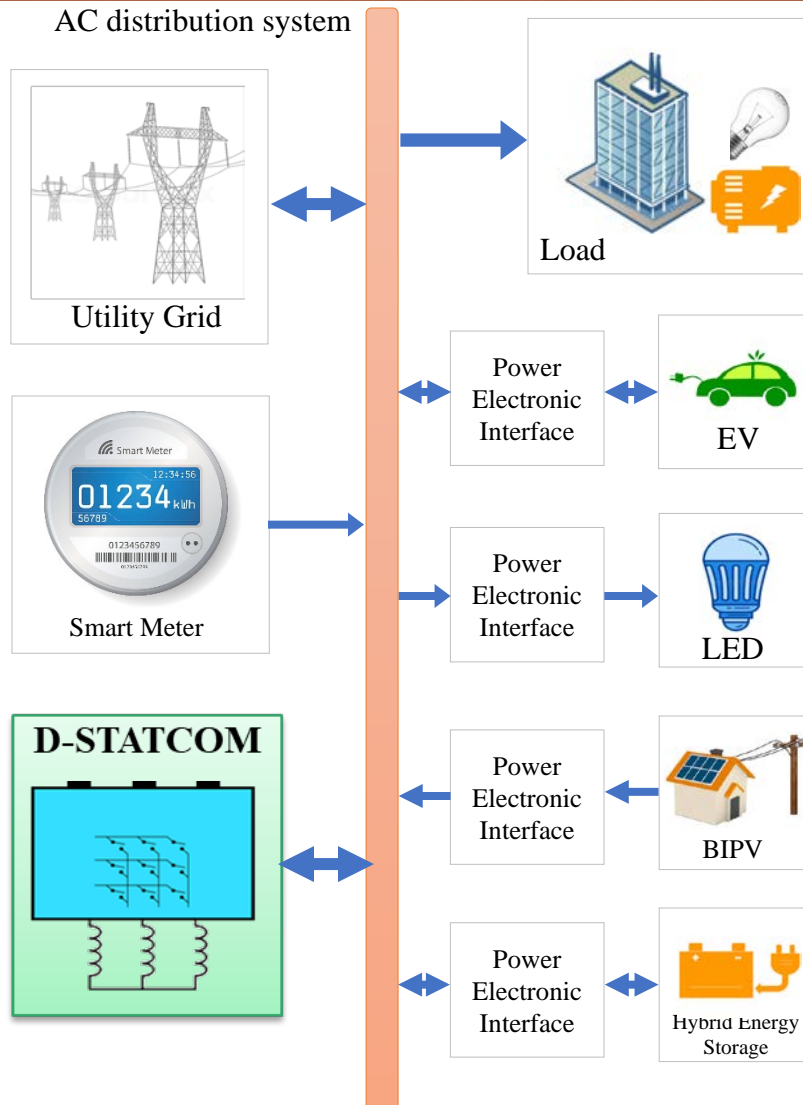

Tomorrow, distributed generation and non-linear loads become dominant. Power Quality is corrected (compensated) near the source in the low-voltage distribution network.

Voltage and current seen by the utility at the substation

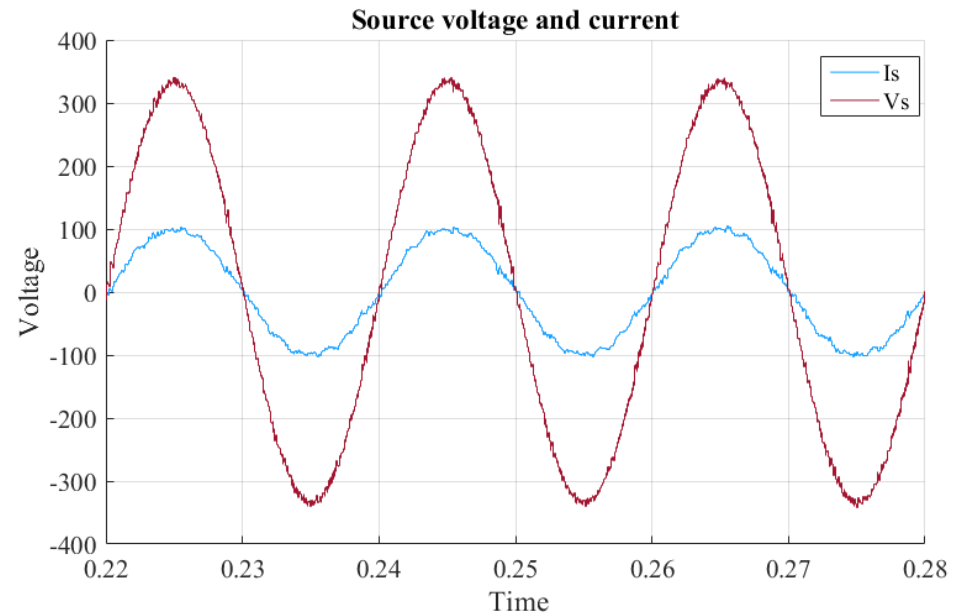

Introduction to the problem

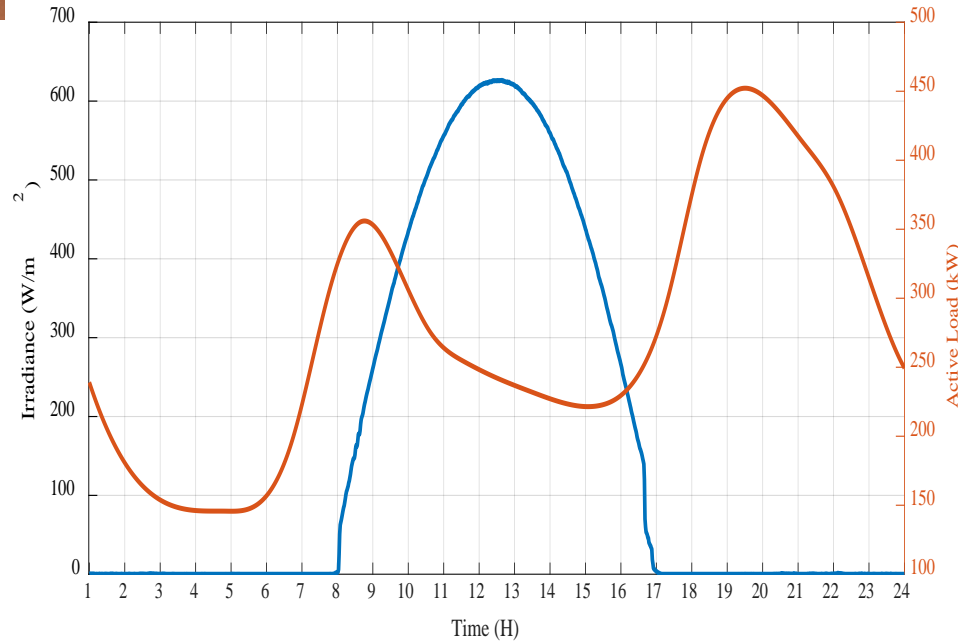

- Corresponding bus voltage plot for a 24 hour period.
- Voltage rise due to PV power injection at noon.
- Smooth variation in voltage.

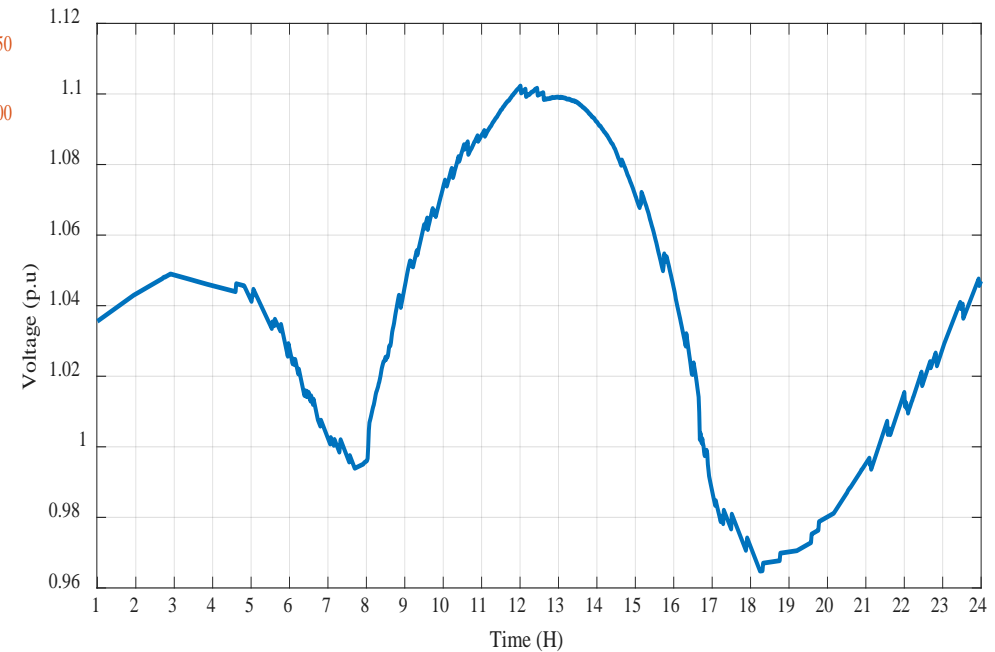

Introduction to the problem

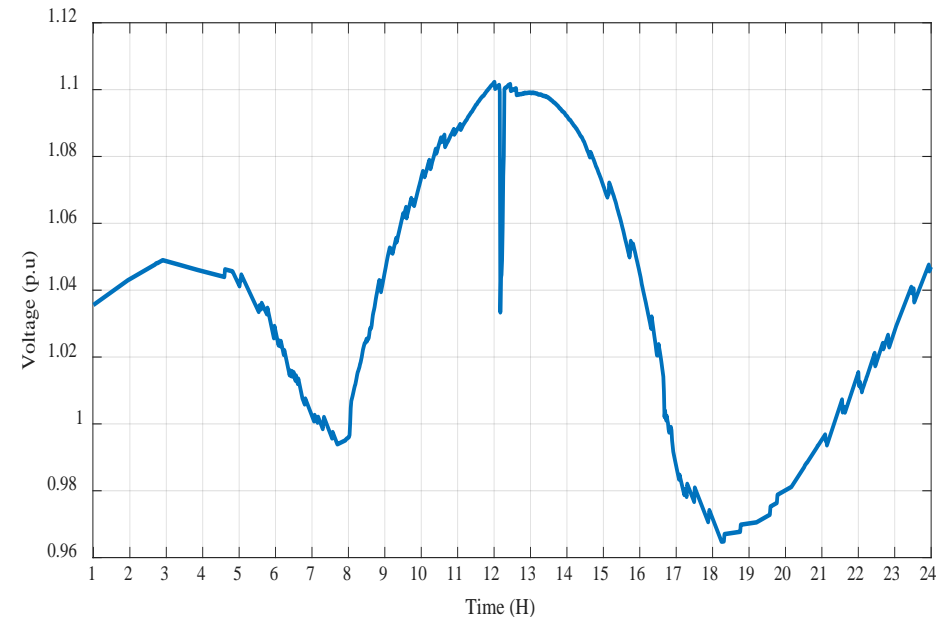
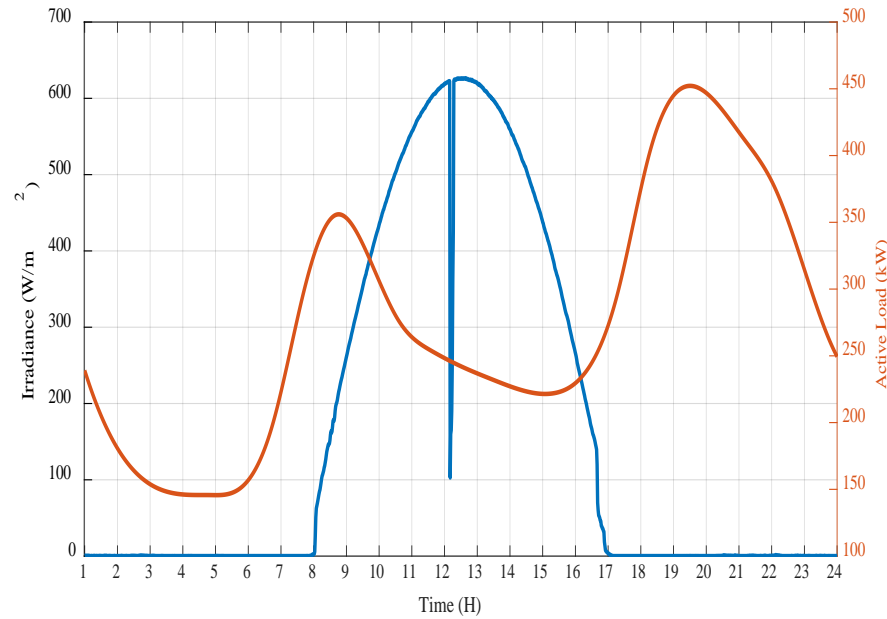

- Corresponding bus voltage plot for a 24 hour period.
- Voltage rise due to PV power injection at noon.
- Dip in voltage due to sudden cloud-transient.

Introduction to the problem

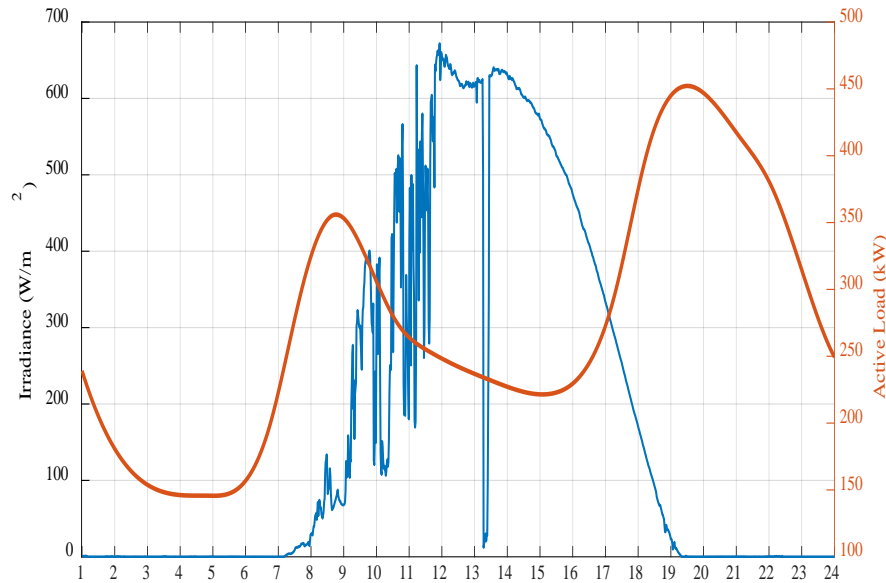

- Corresponding bus voltage plot for a 24 hour period.
- Voltage rise due to PV power injection at noon.
- Fast voltage fluctuations due to highly variable PV power injection

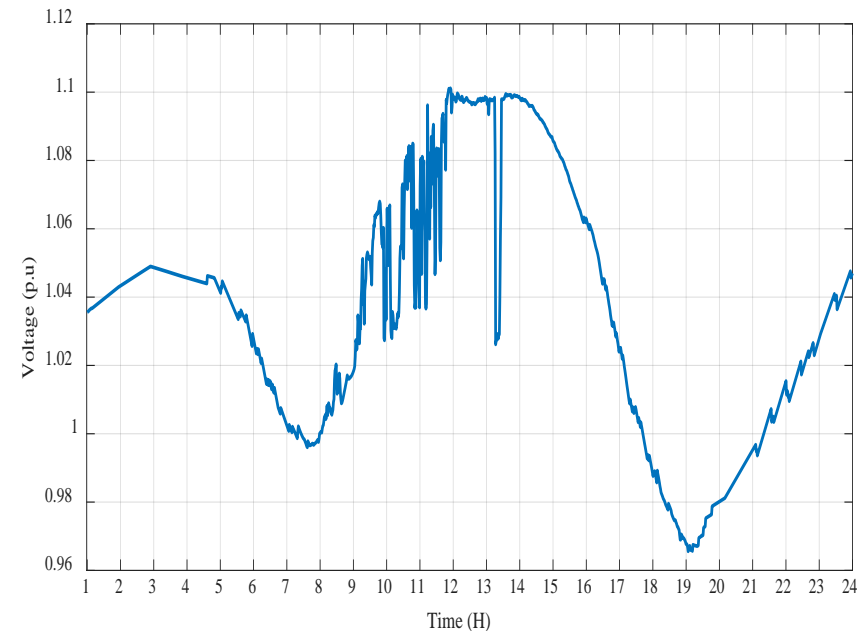

Challenges-Voltage and Aging of Devices

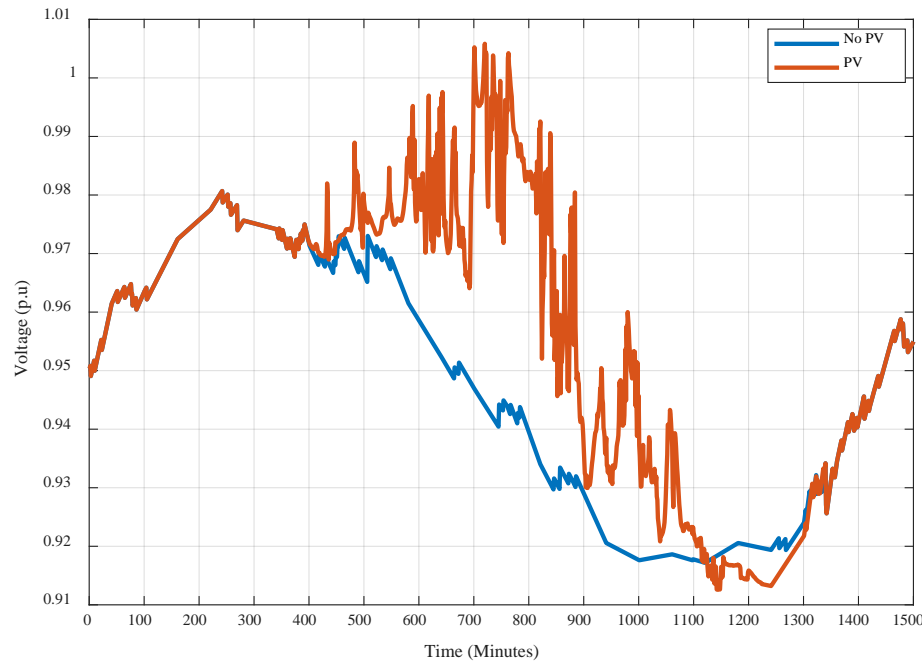

One Day Bus Voltage Profile

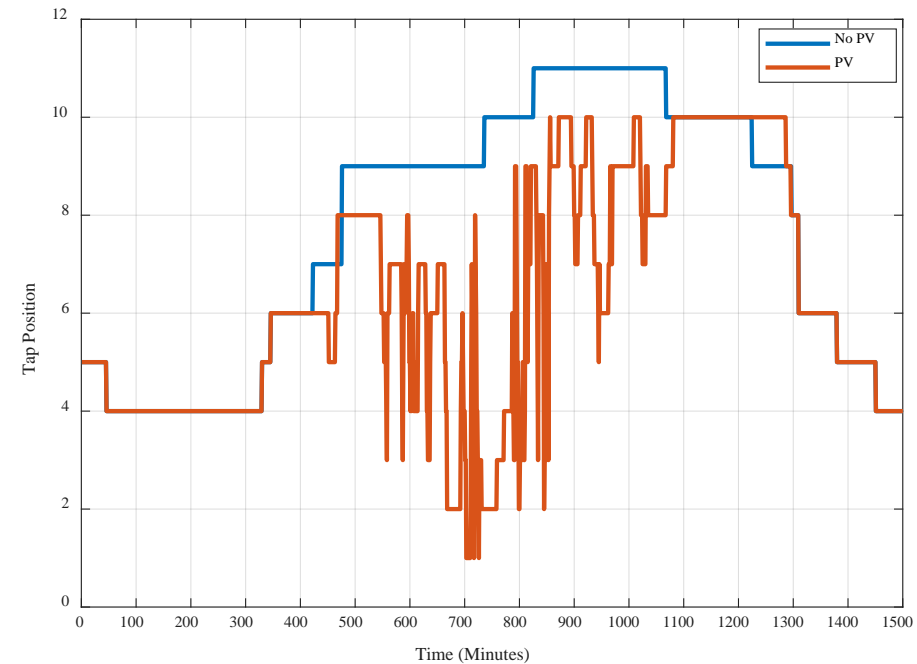

Changes in Tap Position of OLTC

- The stochastic nature of PV generation disrupts the voltage profile.
- Rapid variations in system voltages increases the operational cycles of the OLTC
- Number of operations with no **PV**= 15
- Number of operations with **PV** \approx 205

Introduction to the problem-Challenges

- Rapid changes in voltage and power factor due to unscheduled generation of DERs.
- Accelerated aging of electro-mechanical devices.
- Increase in nonlinear loads and harmonic distortion.
- Increased need for LVRT (Low Voltage Ride Through Capability).
- Mitigation of Short Term Instability Problems.
- Device operation in harsh environments.

Introduction to the problem-Challenges

Solar PV energy consumption, terawatt-hours per year, 2000

Total solar photovoltaic (PV) energy consumption by country or region, measured in terawatt-hours (TWh) per year.

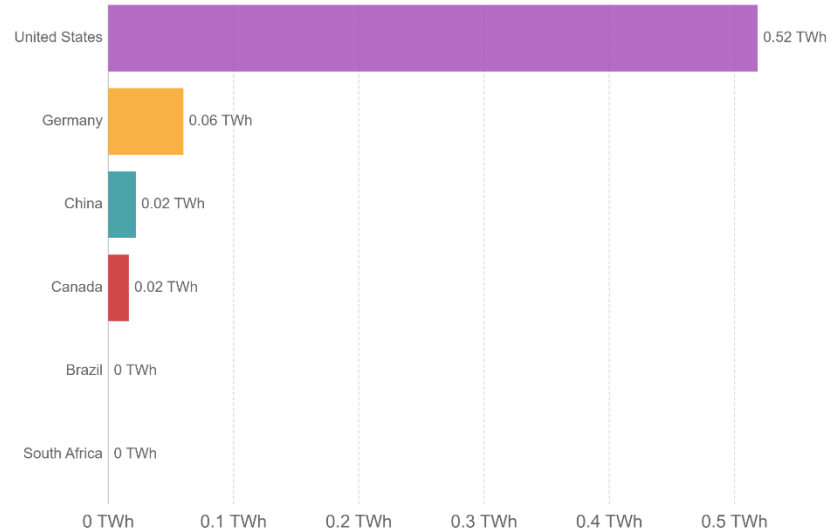

Source: BP Statistical Review of Global Energy

CC BY

Solar PV energy consumption, terawatt-hours per year, 2016

Total solar photovoltaic (PV) energy consumption by country or region, measured in terawatt-hours (TWh) per year.

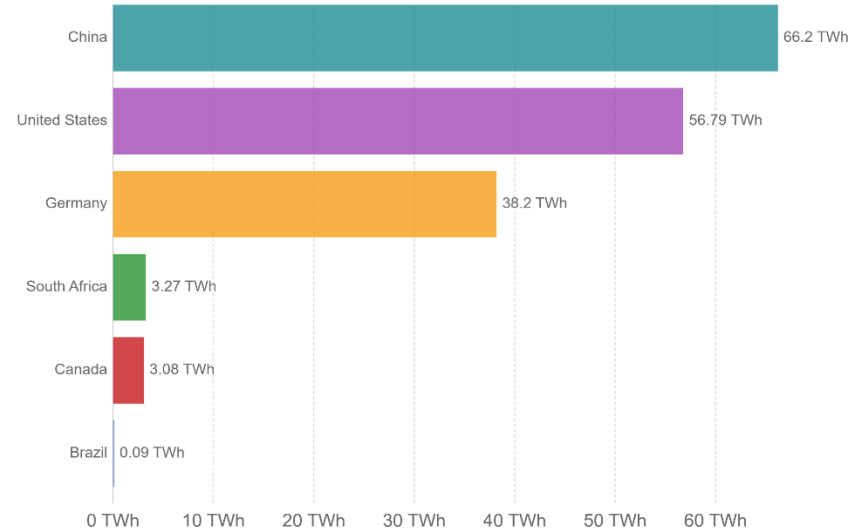

Source: BP Statistical Review of Global Energy

CC BY

U.S. Solar PV Price Declines and Deployment Growth

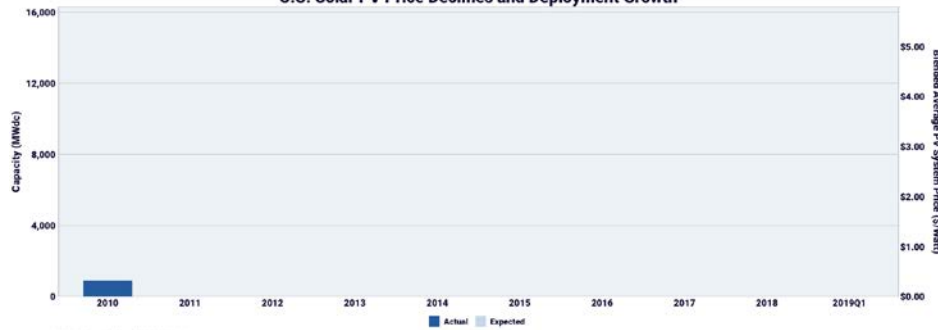

© 2019



According to SEIA & @WM_PowerRenew, total U.S. #solar capacity will more than double over the next 5 years, with annual installations reaching 17.6 GW in 2021! More at seia.org/smi | #TheSolarDecade #SolarIsNow

Projected Installed Capacity in 2021= 69.1 GW

Enough to power 13.1 million American Homes!!

Distribution System Testbed

IEEE 34 Node Test Feeder

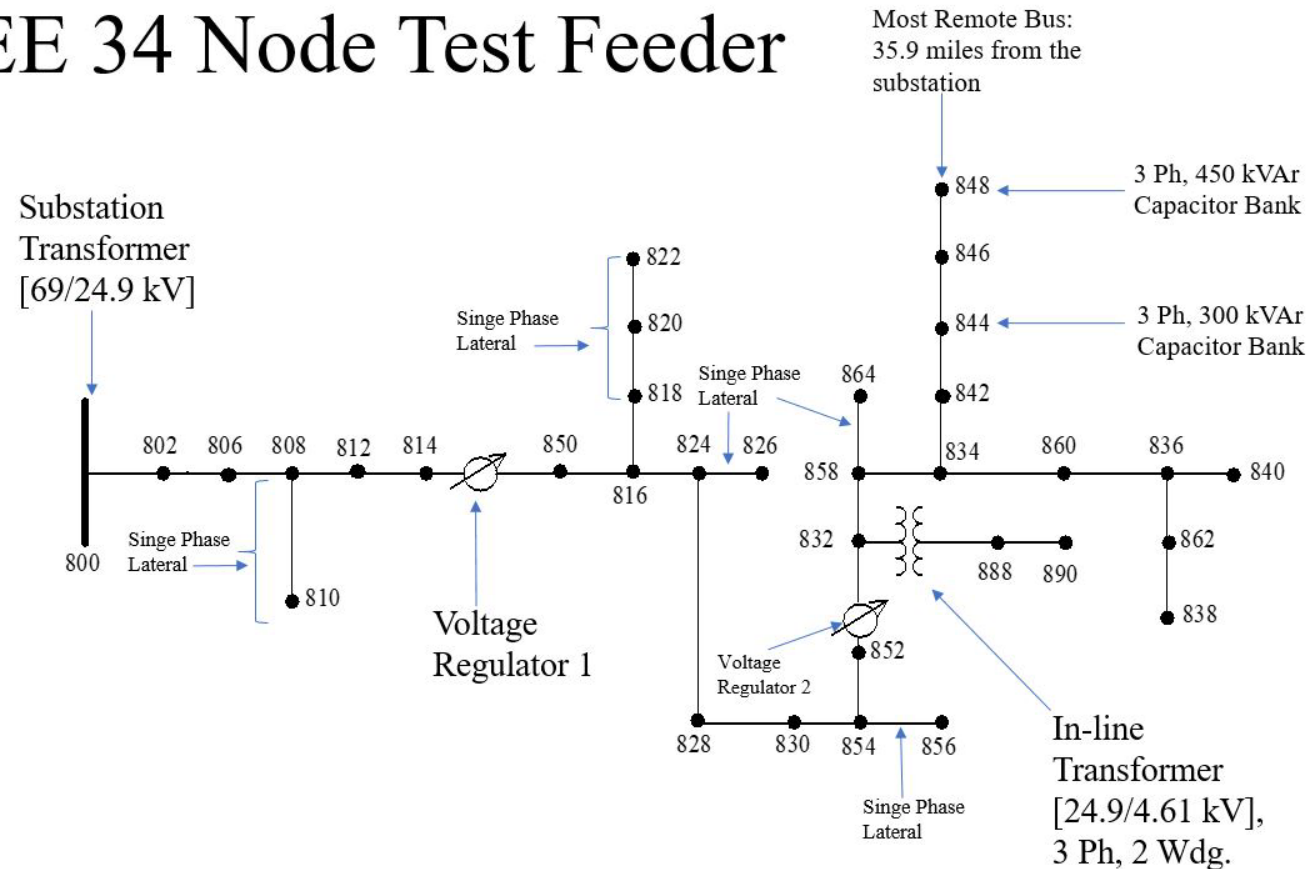

Distribution System Testbed-Voltage Control

- OLTC at the substation transformer
- VRs in the downstream laterals.
- Capacitor banks.

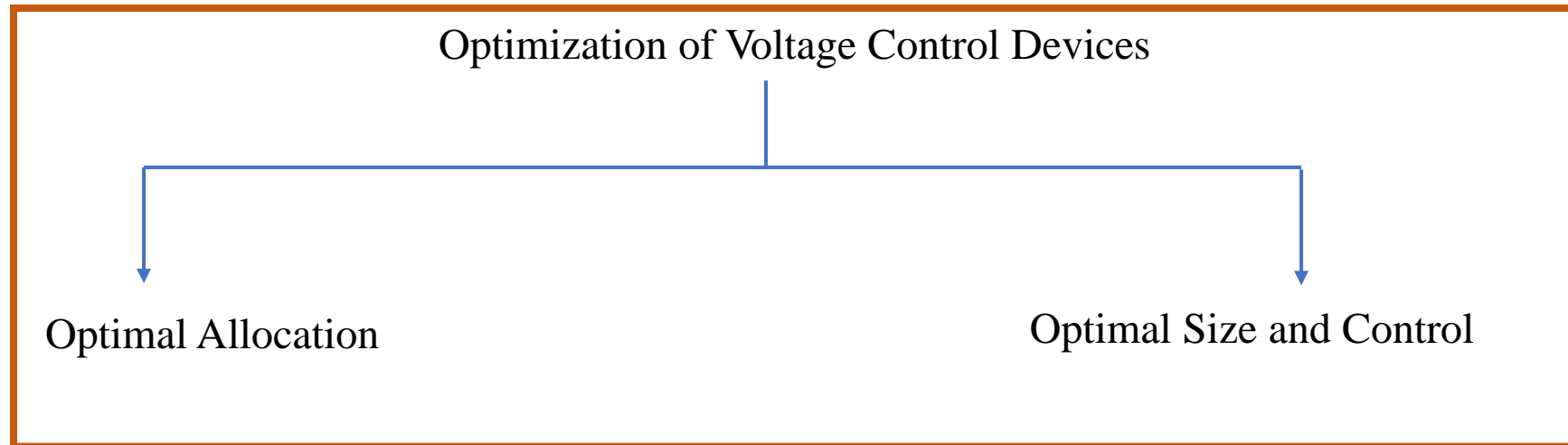

Distribution System Testbed- OLTC

LTC at the Substation Transformer

- Use of Line Drop Compensation.
- $R' + jX' = (Z_{line}) \cdot CT_p / N_{pt} \text{ V}$
- $Z_{line} = (V_{reg} - V_{lc}) / I_{line}$
- Bus 802 is the control load center voltage.

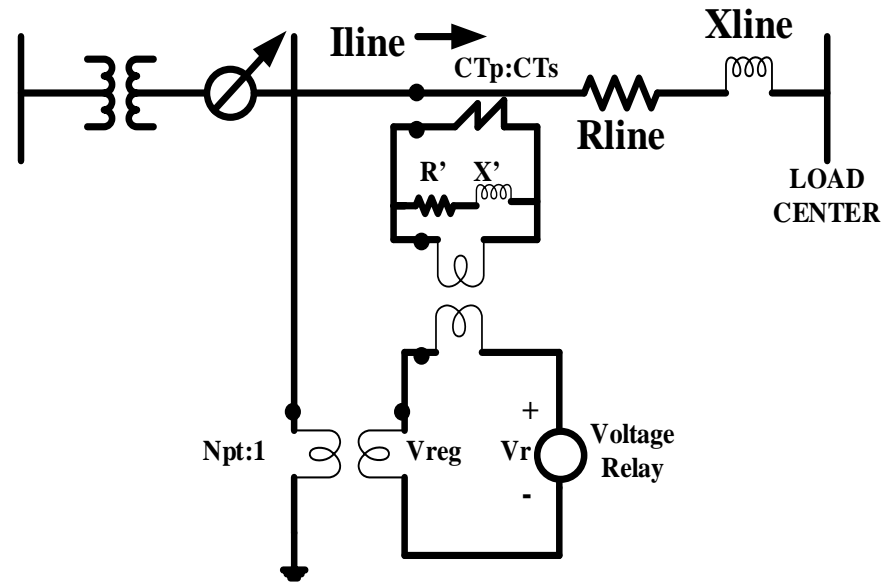

Line Drop Compensator Circuit

Device	Vreg	Band	Npt	CTp	R'	X'	Rline (Ω)	Xline (Ω)	Time Delay
LTC	126 V	1 V	120	600	3 V	1 V	0.588	0.072	15 sec

Distribution System Testbed-Voltage Regulators

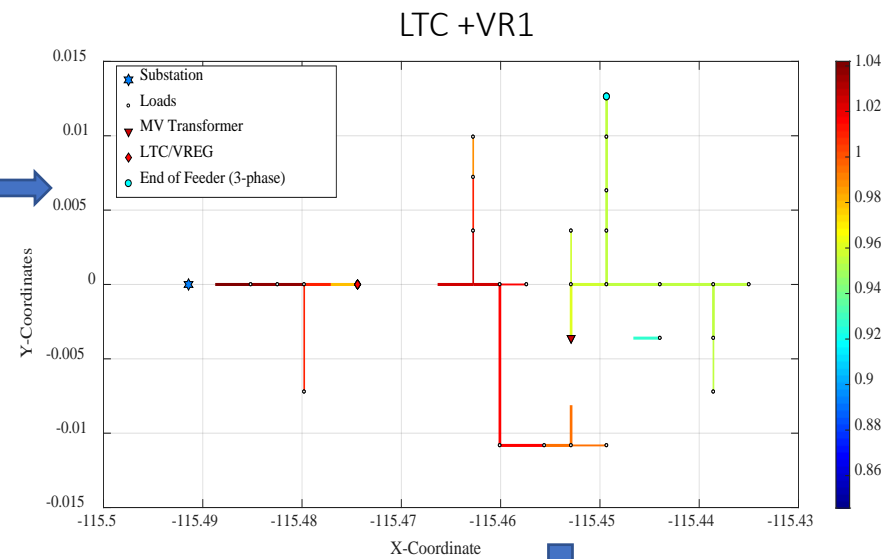
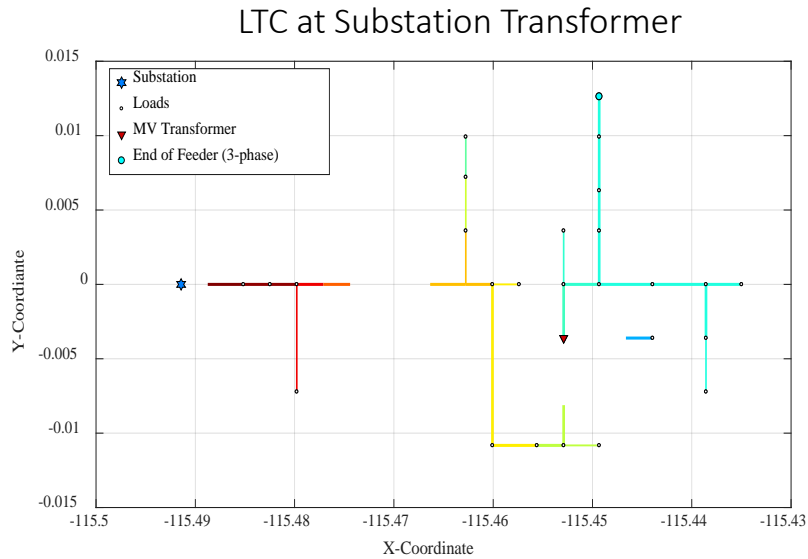

Optimal Procedure of VRs Placement

- Locate the first bus nearest to the substation with $V < 0.95$ p.u
- Set the appropriate voltage, bandwidth and delay settings.
- Run a snap shot power flow.
- Repeat, if any bus reports $V < 0.95$

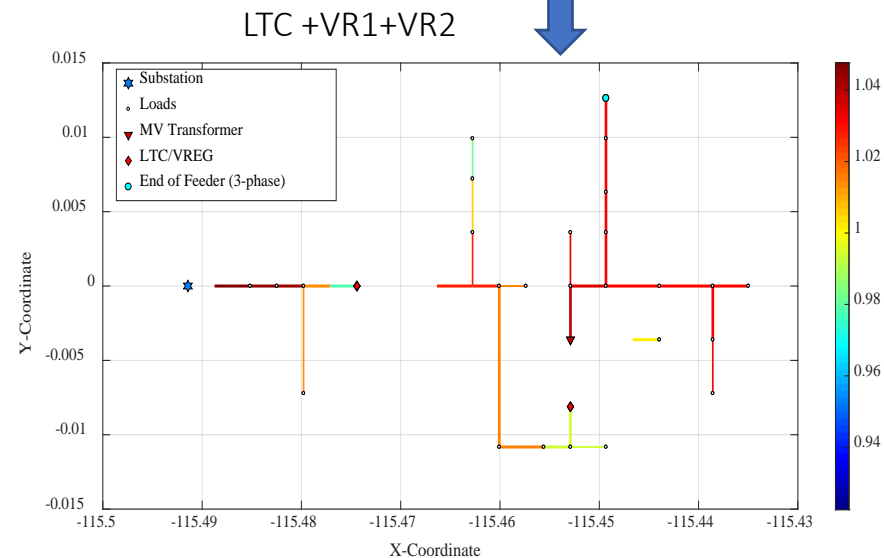

Distribution System Testbed- Capacitor Banks

- Objective: Loss minimization.
- Constraints: Nodal Voltages and Substation power factor.

$$\begin{aligned} & \text{minimize} \sum_{(i,j) \in T} p_{ij}(\tau) = |I_{ij}(\tau)|^2 r_{ij} \\ & \text{subject to } V_{min} \leq V_i \leq V_{max} \\ & \quad \quad \quad pf_{ss} \geq pf_{min} \end{aligned}$$

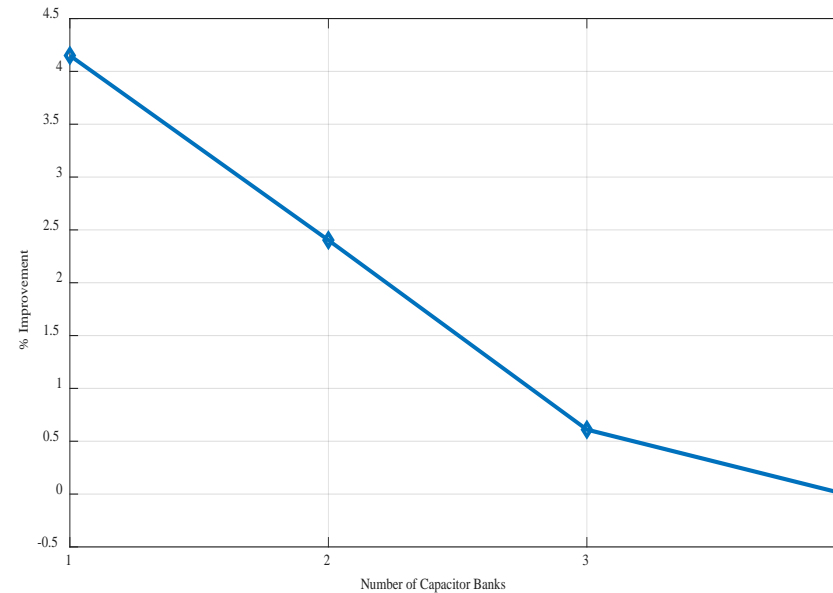
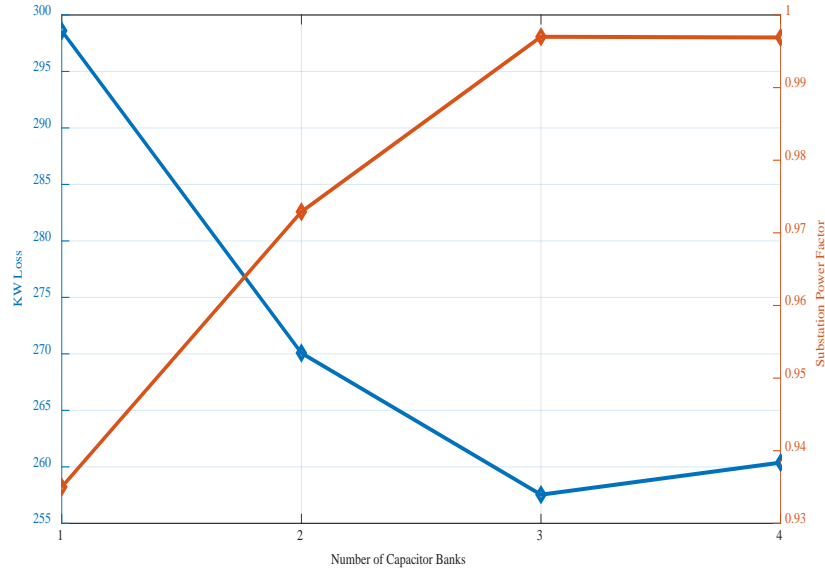

Distribution System Testbed-Capacitor Banks

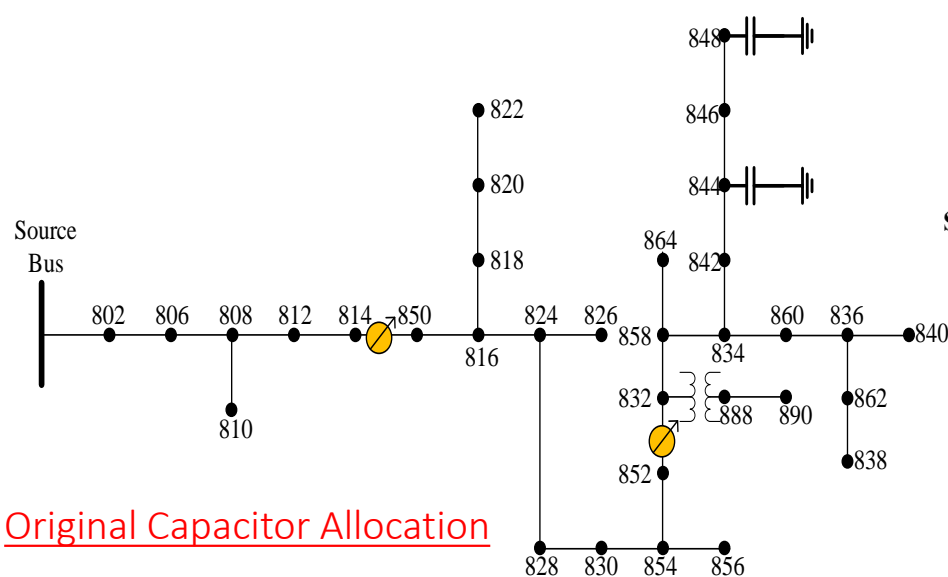

Original Capacitor Allocation

Source Power Factor	0.9906
KW Loss	270
KVAR Loss	63
KVAR source	281

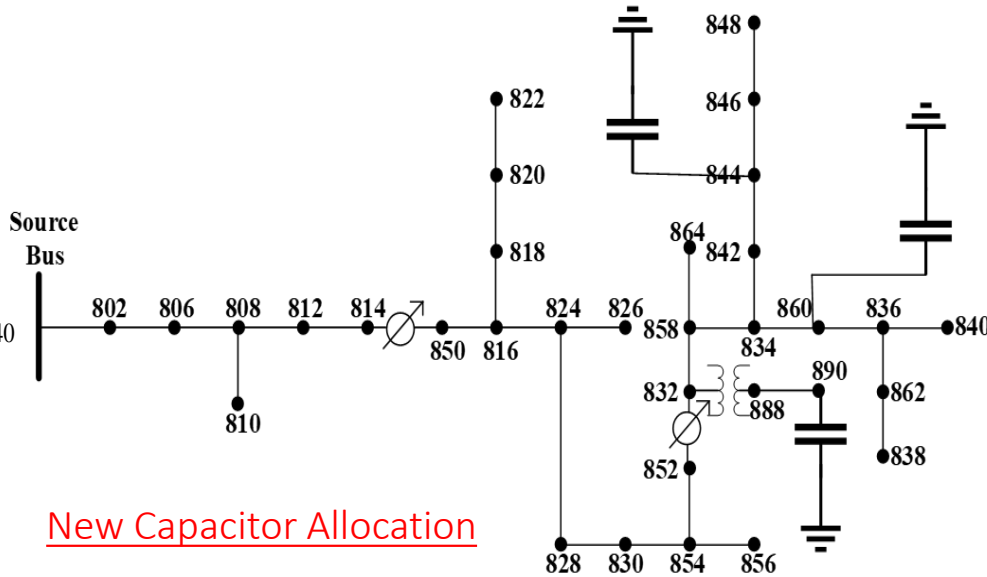

New Capacitor Allocation

Source Power Factor	0.9969
KW Loss	259
KVAR Loss	53
KVAR source	163

Optimal Placement of Capacitor Banks

Distribution System Testbed-Voltage Control

- Control of Tap Changing Transformere
 - Voltage Set point
 - Bandwidth
 - Time Delay

Device	Vreg	Band	Time Delay
VREG1	123.5 V	2 V	30 sec
VREG2	124 V	2 V	45 sec

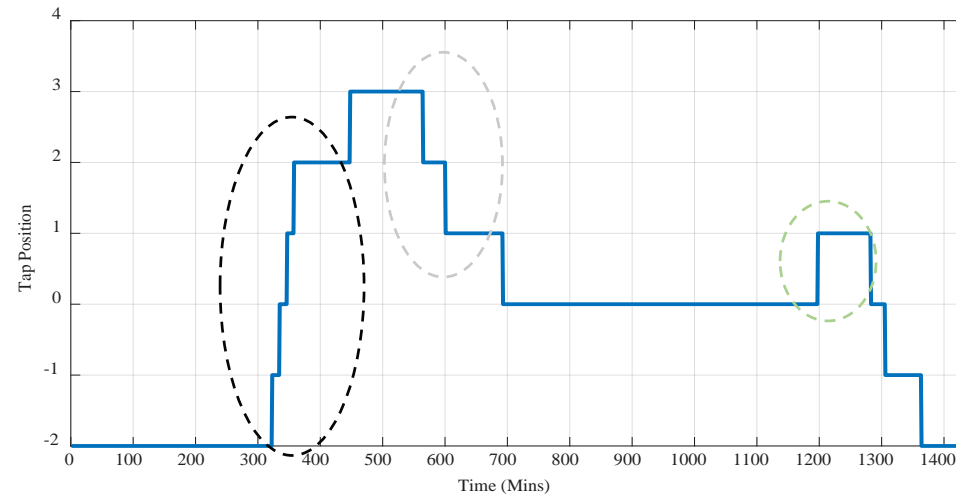
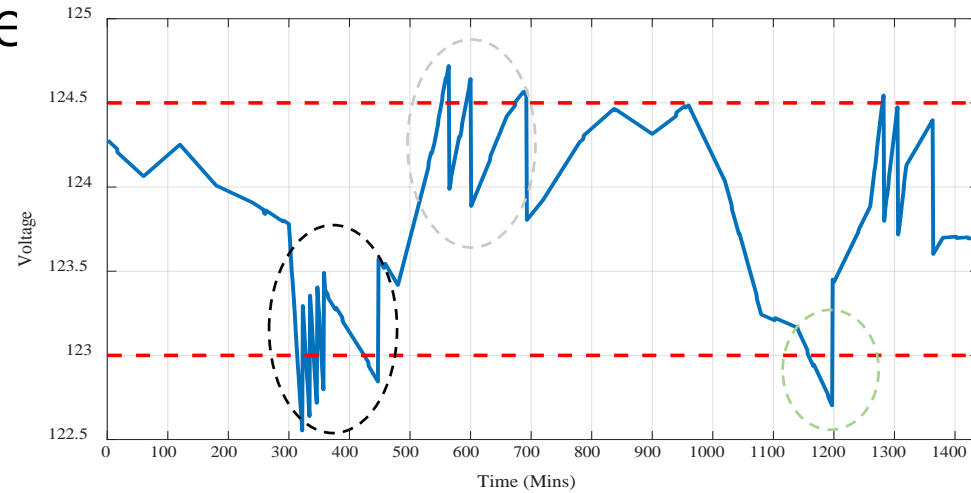

Distribution System Testbed-Voltage Control

- Control of Capacitor Banks
 - Voltage control of Cap 890
 - Timer control of Cap 844 and 860

Cap. Bank	ON Setting	OFF Setting
C890	$V < 1.0$ p.u	$V > 1.05$ p.u
C844	1700 Hours	1130 Hours
C860	1700 Hours	1130 Hours

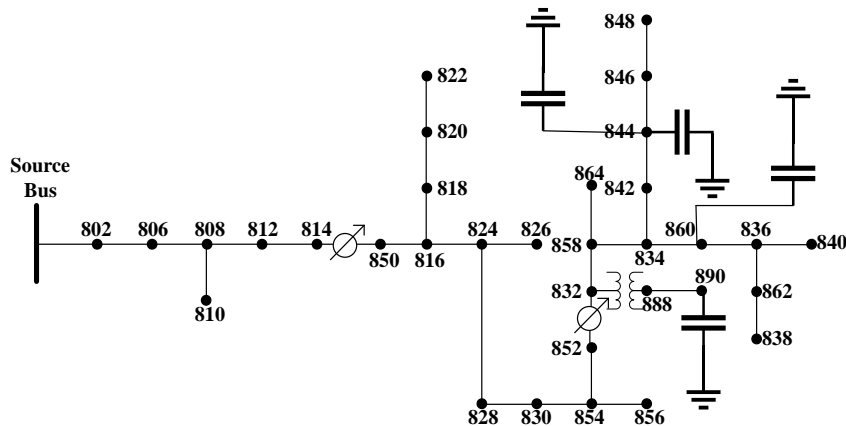

Voltage Control

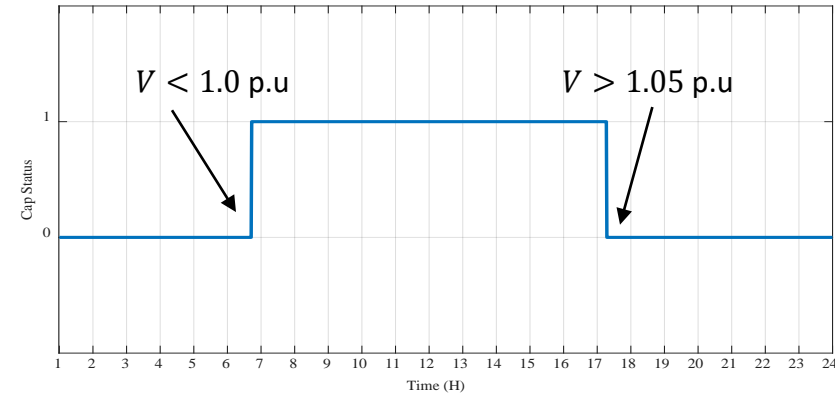

Timer Control

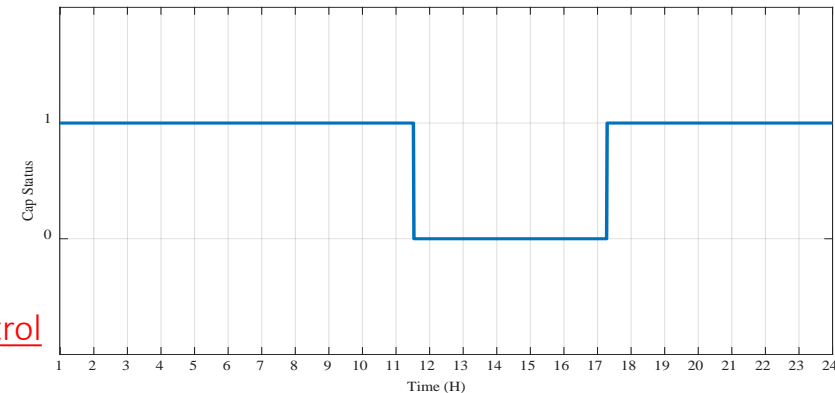

Distribution System Testbed-Scenarios

Three operational scenarios:

- Light load condition and small to zero PV injection [1].
- Peak PV injection and average load injection [2].
- Peak load condition and small to zero PV injection [3].

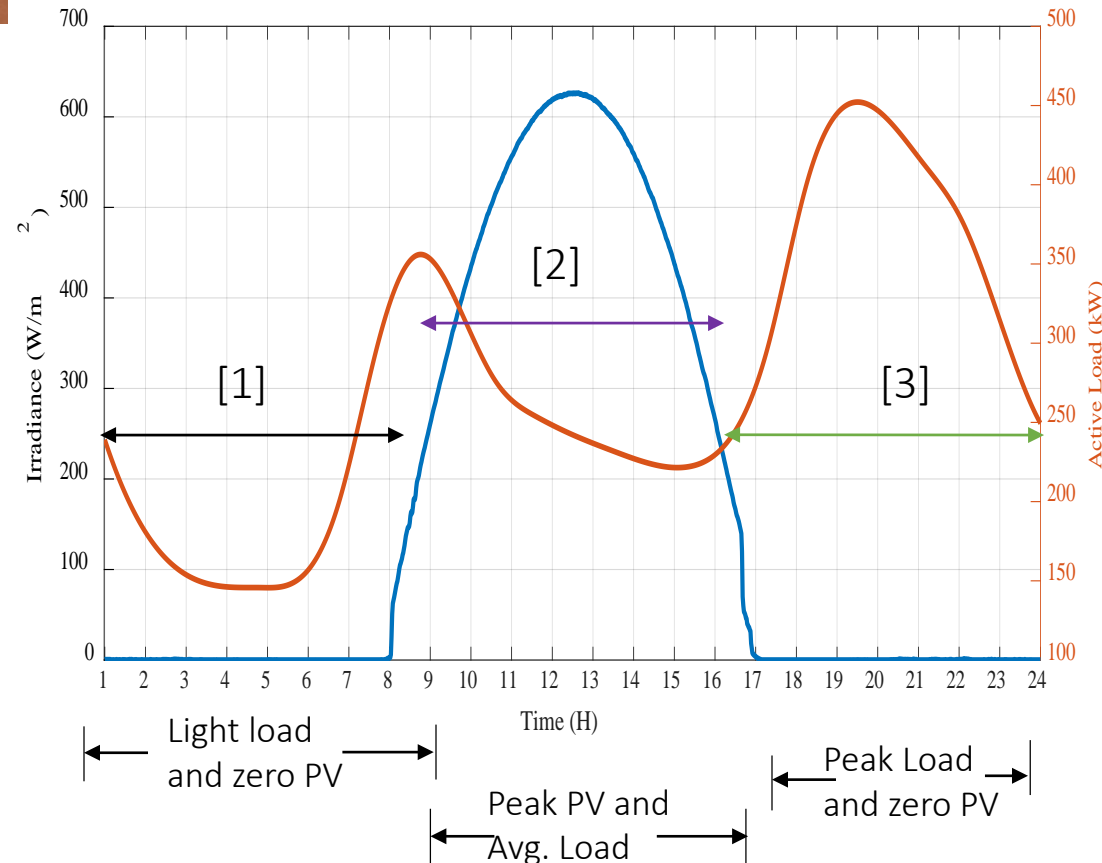

Distribution System Testbed-Light Load

- Snapshot Simulation at Light Feeder Load [20% of Peak Load].
- Peak Load=2.04 MW

Device	V_{sp} (p.u)
OLTC	1.04
VR-1	1.025
VR-2	1.03

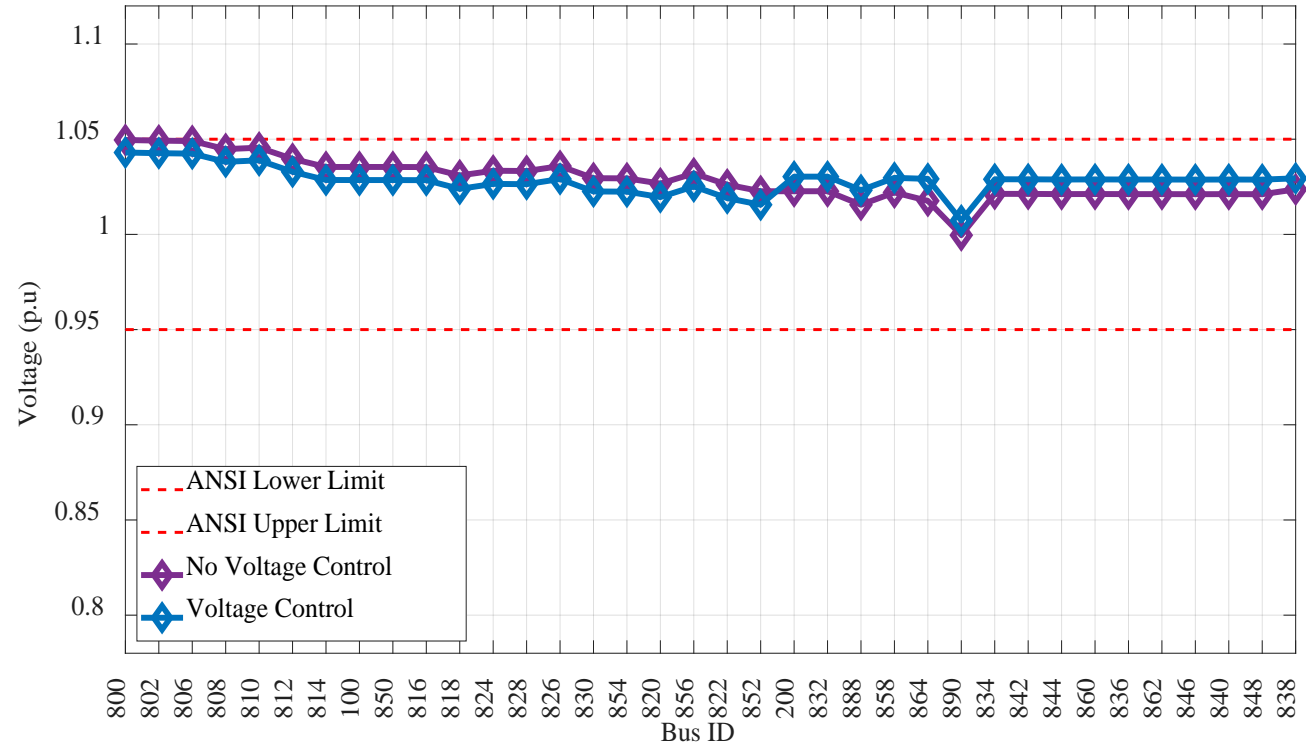

	Substation PF	kW Loss [%]	kVAr Source
No Voltage Control	0.99	3 %	52 kVAr
Voltage Control	0.9888	2.8 %	56 kVAr

Distribution System Testbed-Peak PV + Moderate Load

- Snap Shot Simulation
- Peak PV = 1.59 MW
- Load= 1 MW [50 % of Peak]
- Back Feeding.

Device	V_{sp} (p.u)
OLTC	1.025
VR-1	1.025
VR-2	1.025

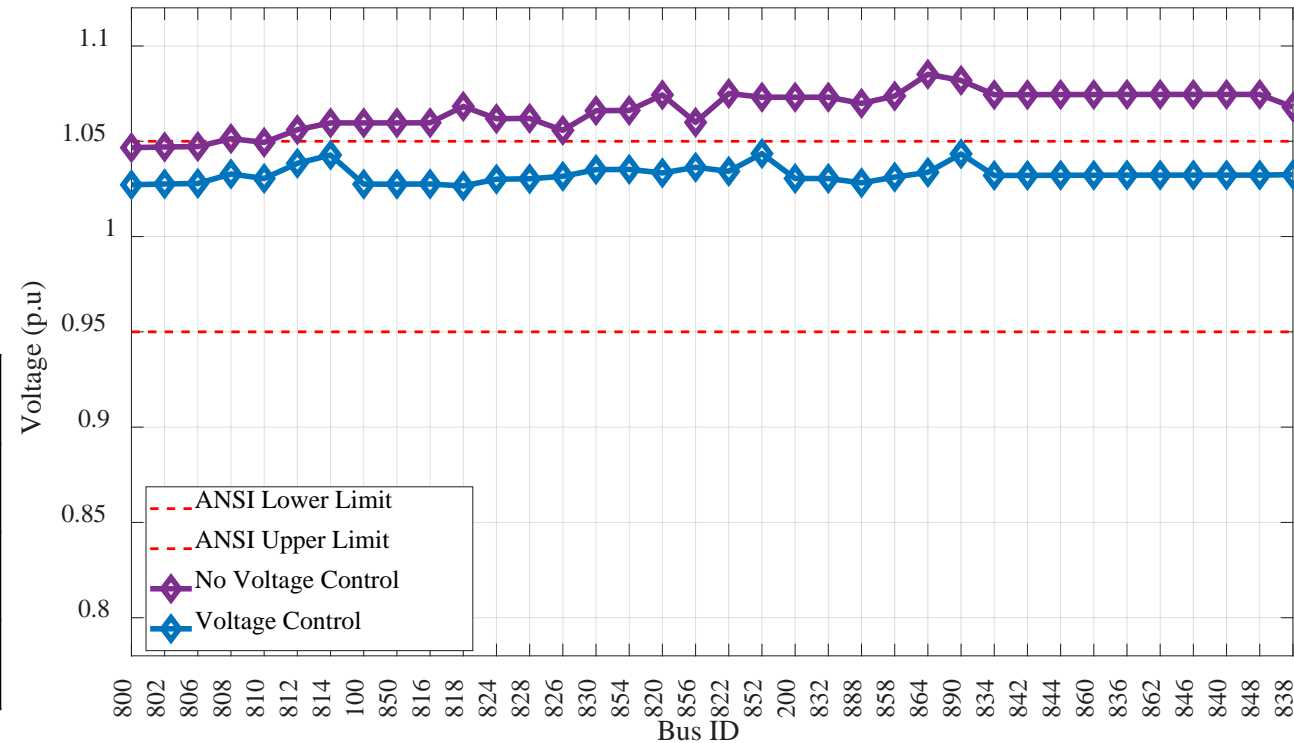

	Substation PF	kW Loss [%]	kVAr Source
No Voltage Control	-0.8626	7.2 %	435 kVAr
Voltage Control	-0.9	7.3 %	413 kVAr

Distribution System Testbed-Peak Load

- Snap Shot Simulation at Peak Feeder Load= 2.04 MW

Device	V_{sp} (p.u)
OLTC	1.04
VR-1	1.025
VR-2	1.03

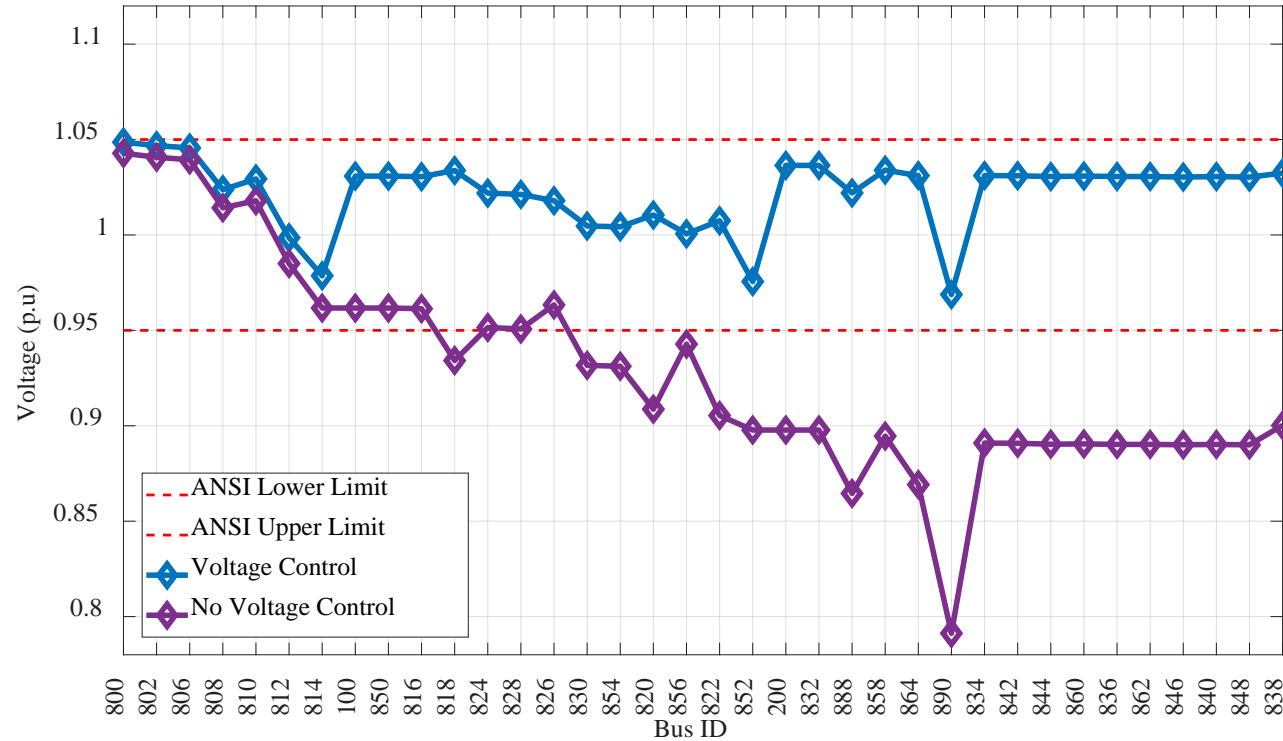

	Substation PF	kW Loss [%]	kVAr Source
No Voltage Control	0.8857	15.1 %	924 kVAr
Voltage Control	0.9968	12.7 %	56 kVAr

Distribution System Impact: Use Cases

Quasi-Static Time Series (QSTS)-Simulations

- Sequential steady state power flow simulations.
- Converged state of each time step is used as the beginning of next step.
- Time-dependent aspects of distribution systems.
- Interaction of load injections and PV injections with the voltage control devices.

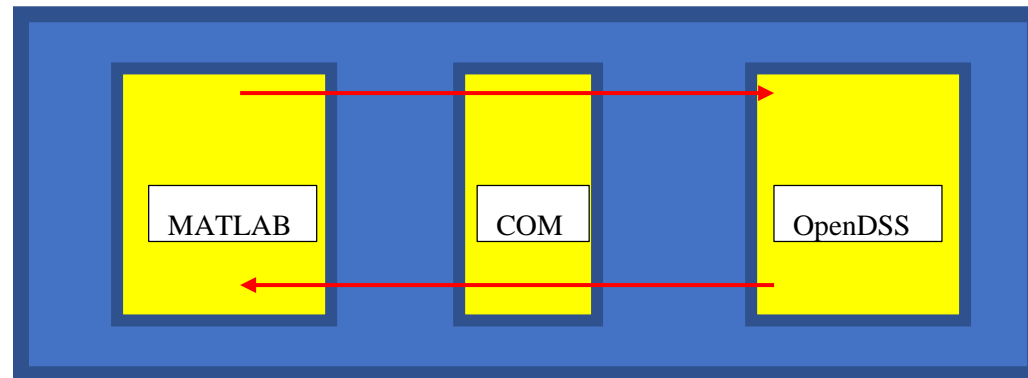

QSTS Simulations- Load Data

kW_p	Load Type	Number
≤ 3	Residential, Low Load (Apartment, Studio etc.)	13
$3 \leq kW \leq 10$	Residential, High Load (House with more than 3 bedrooms)	24
$10 \leq kW \leq 25$	Commercial, Small (Small Store)	20
$25 \leq kW \leq 100$	Commercial, Medium (Small Office, Retail Store etc.)	8
$100 \leq kW \leq 500$	Commercial, Large(Super Market, Hotel etc.)	2

- Hourly Residential and Commercial Load Profiles from DOE.
- Residential Data based on Residential Energy Consumption Survey.
- Commercial Data based on DOE commercial reference building models.
- 37 Residential Profiles and 30 Commercial Profiles

QSTS Simulations- Load Data

Location	Annual Average Electric Usage per Household (kWh/y)
IEEE 34 Test Model	12898
State of Arizona	13550
United States	10399

- Normalization is done based on individual kWp values.

$$NF_i(t) = \frac{kW'(t)}{kW_{i,p}}$$

- $NF_i(t) \in (0,1]$
- Uncorrelated load behavior.

QSTS Simulation-Solar Data and PV Model

- 1 minute NREL Solar Irradiance data.
- 1 minute temperature data.

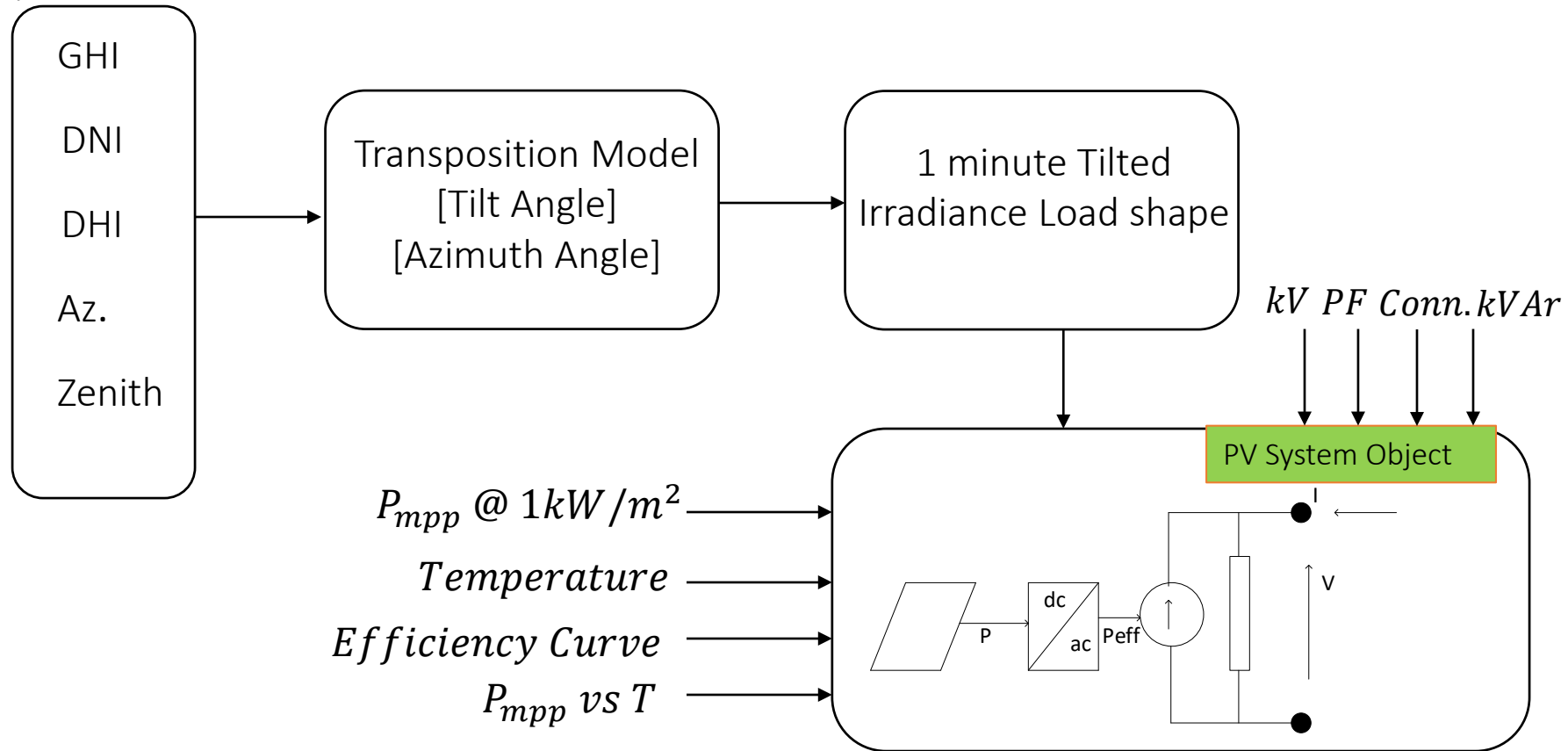

QSTS Simulation-Solar Data and PV Model

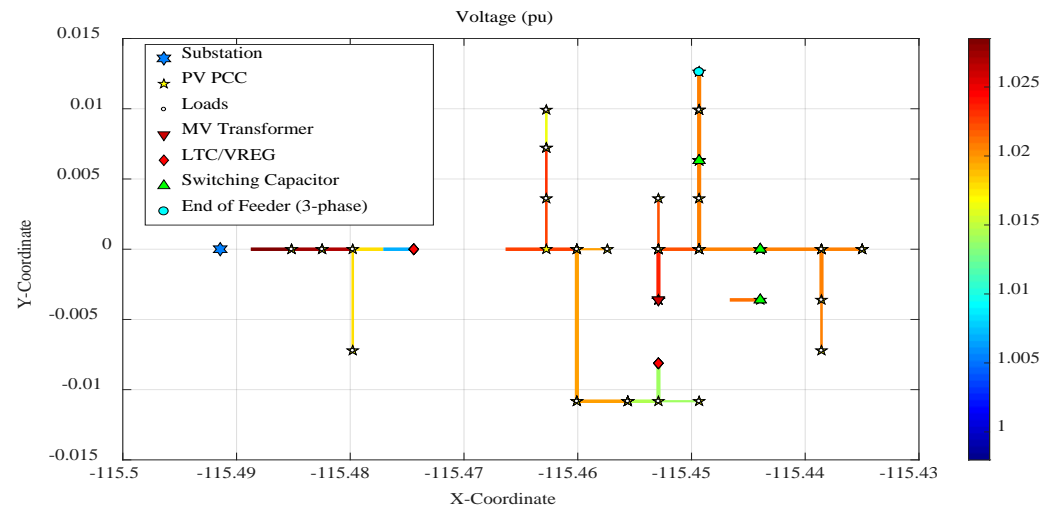
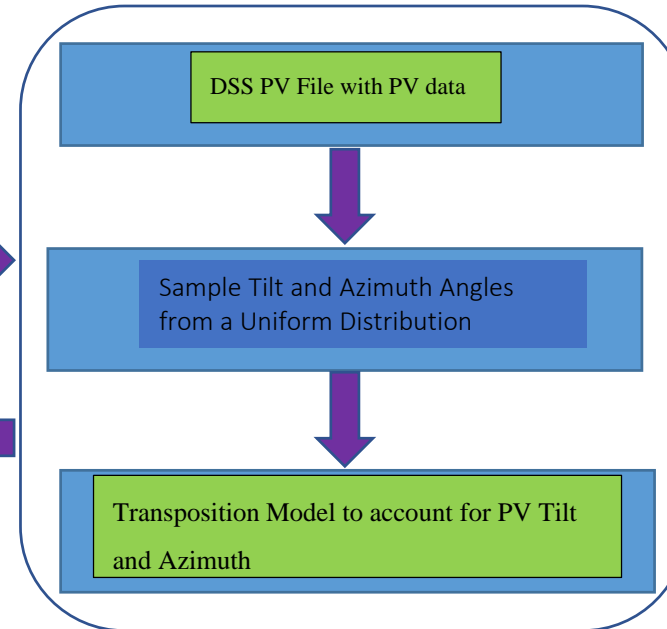
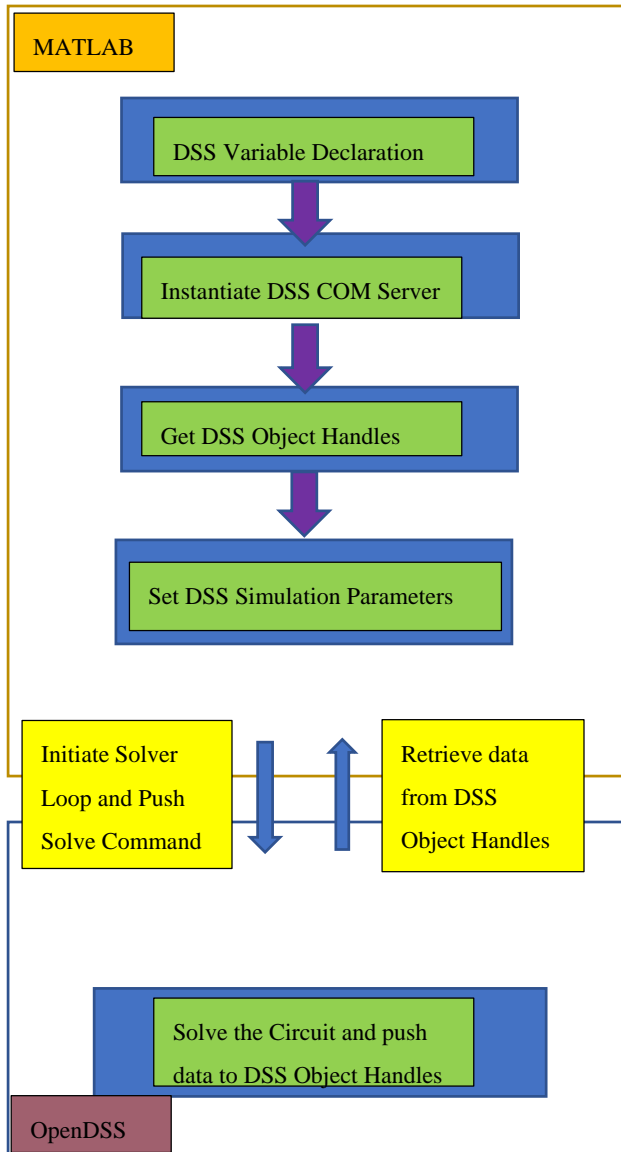

PV Inverter Voltage Support

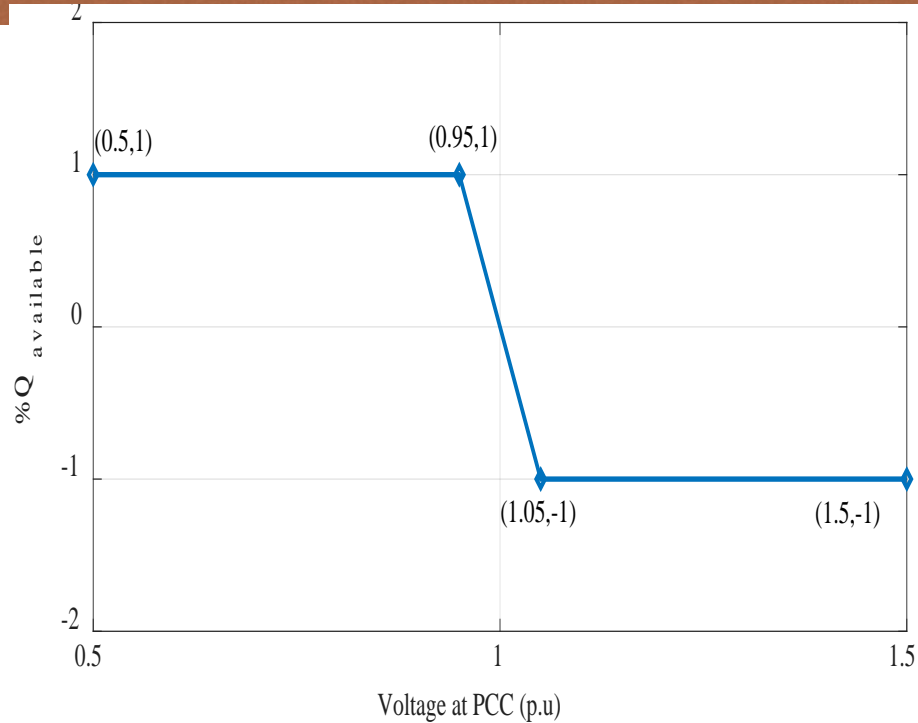

Volt-VAR Curve

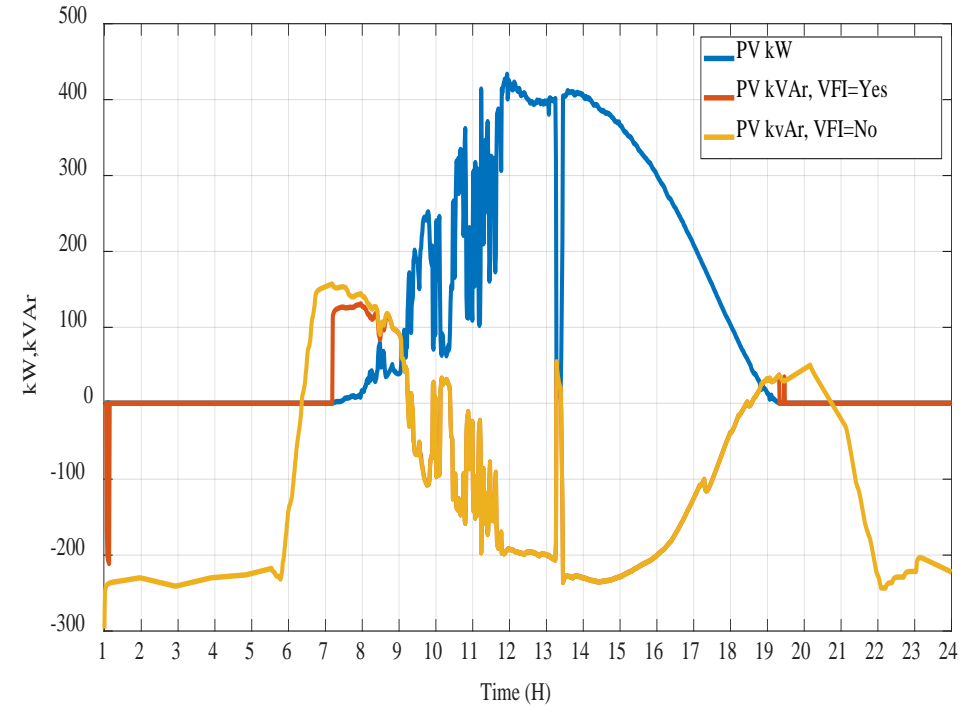

PV kW and kVAR

- With VFI [VarFollowInverter]=Yes, the PV inverter does not regulate the voltage when PV kW=0.
- With VFI=No, the PV inverters regulate PCC voltage even when PV kW=0

Power System Impact: Use Cases

Use Case Name	Impact Type	Peak Load Level	Peak PV Level	% PV Penetration	PV Control Type
Case 1	Load Change Only	2.04 MW	0 MW	0 %	-
Case 2A	Load+PV Injection	2.04 MW	0.6 MW	30 %	Unity PF*, Non-unity [^] PF and Volt-Var
Case 2B	Load+PV Injection	2.04 MW	1.63 MW	80 %	Unity PF, Non-unity PF and Volt-Var

*PF= Power Factor

[^]Refers to constant non-unity power factor operation

Use Case 1: Impact of Load Variability

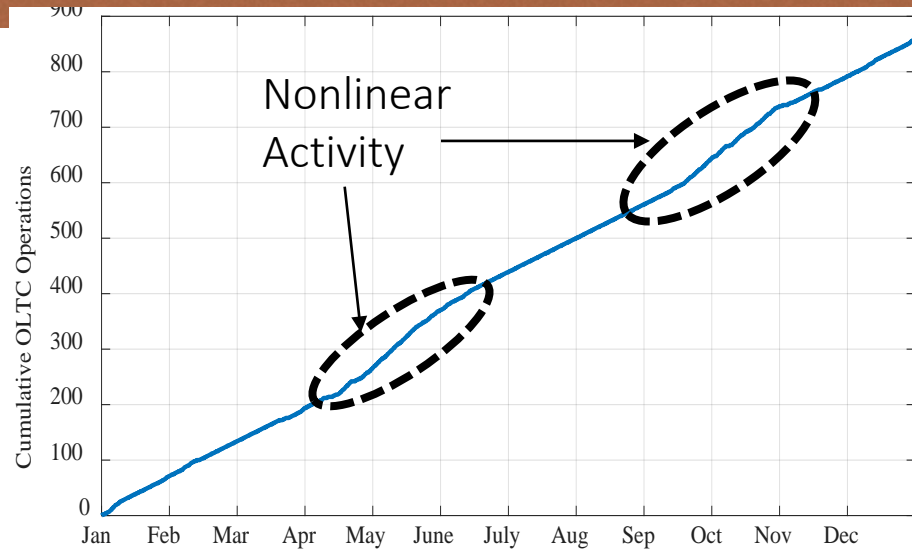

OLTC Cumulative Operations

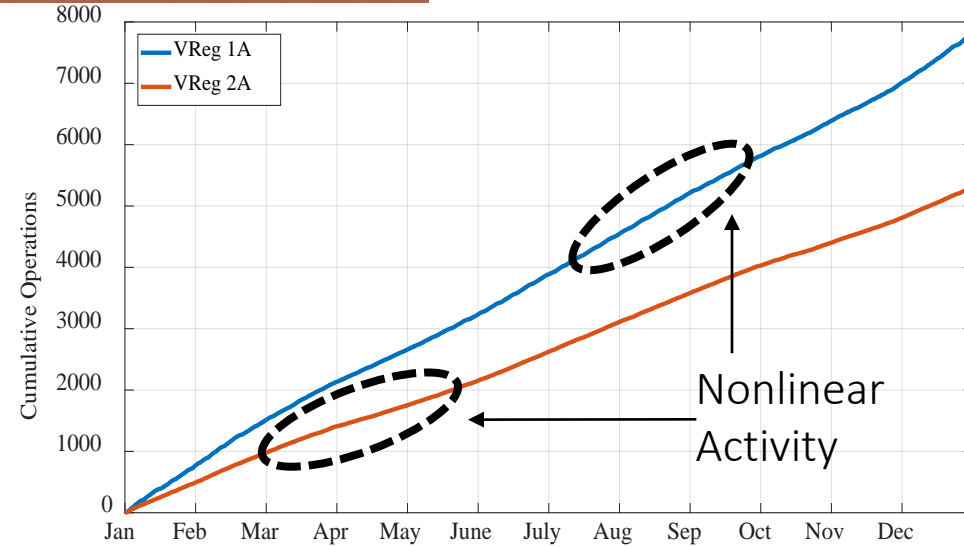

VReg Cumulative Operations

Device	Annual Operations	Daily Operations
OLTC	730	2
VReg 1A	7290	≈ 20
VReg 1B	4795	≈ 13
VReg 1C	5140	≈ 14
VReg 2A	5143	≈ 14
VReg 2B	4750	≈ 13
VReg 2C	5055	≈ 14

Use Case 1: Impact of Load Variability

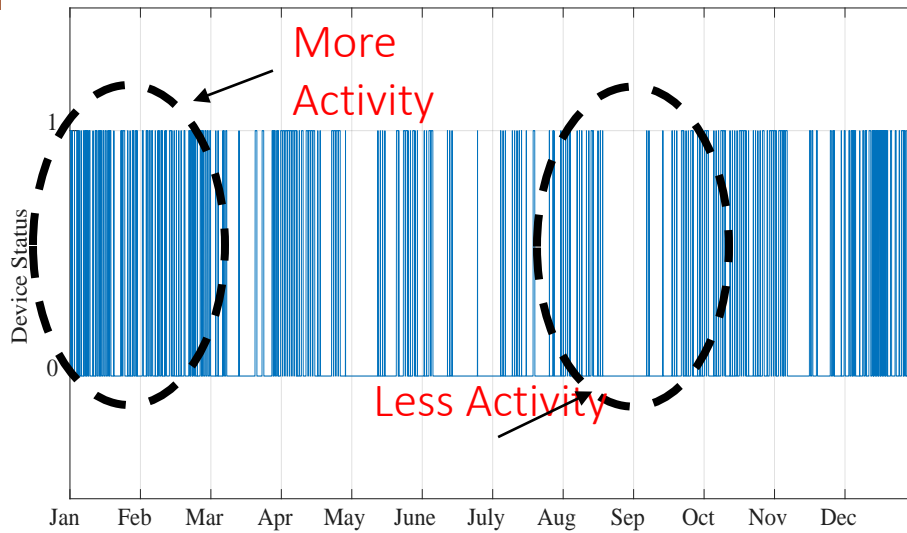

Capacitor Bank 890
Switching Profile

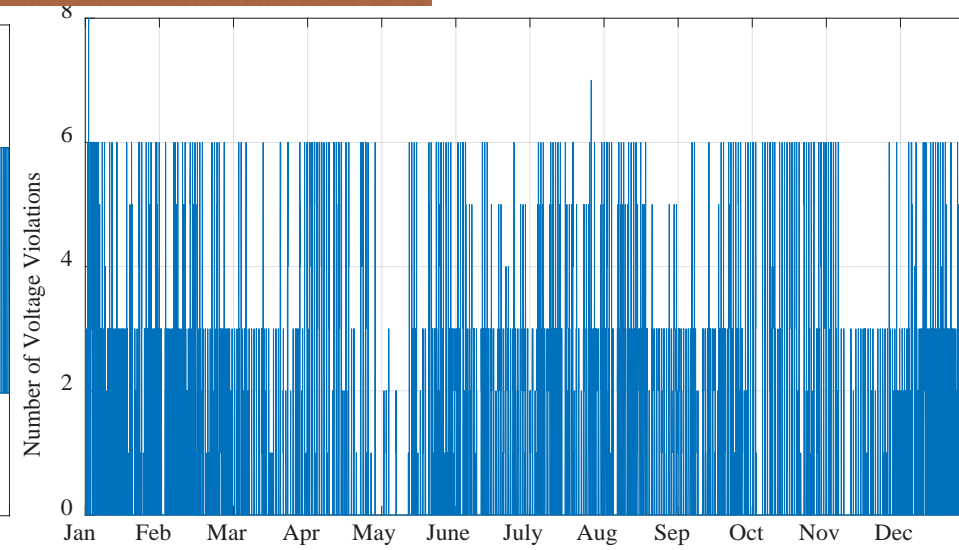

Voltage Violations

- Annual number of Capacitor Operations = 604
- No more than 6 voltage violations on a given day.
- Non-uniform Capacitor Operation.

Use Case 2a.1: Low Penetration PV @ PF=1

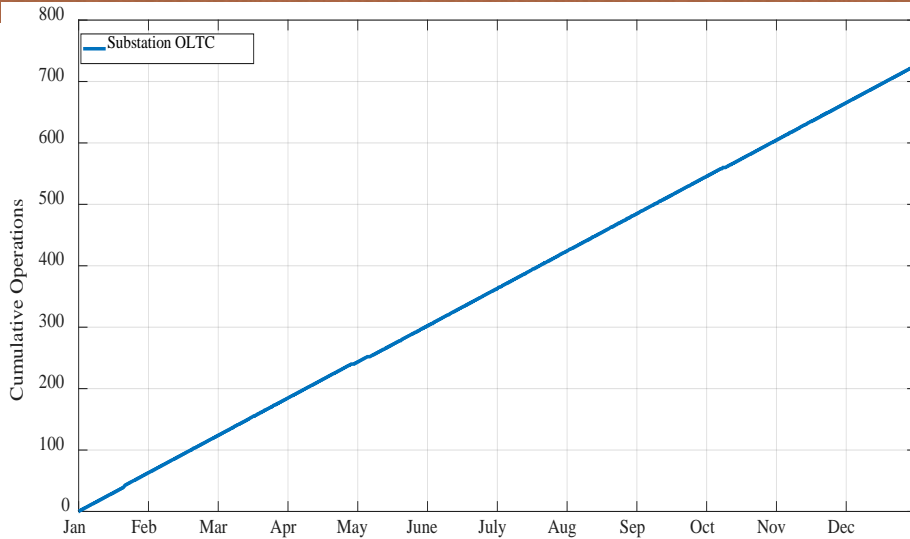

OLTC

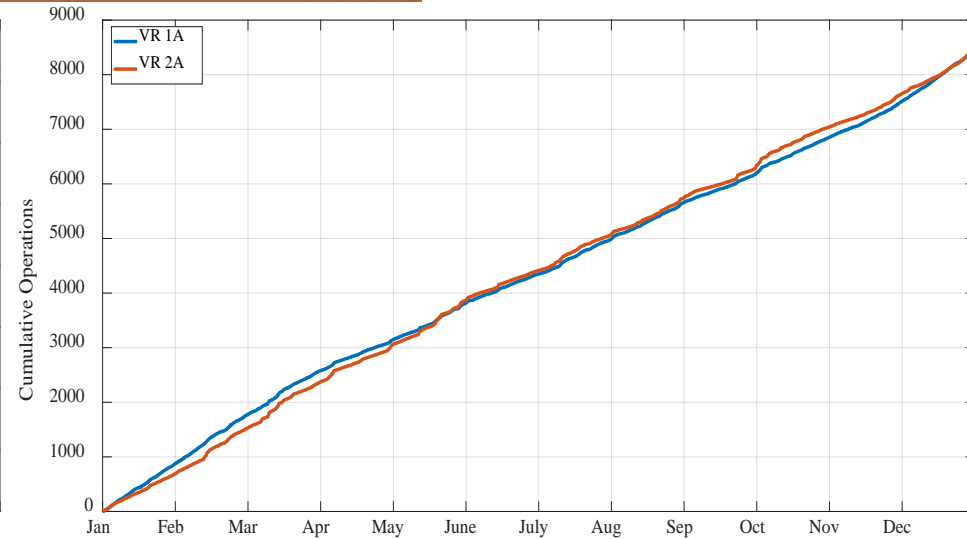

Line Regulators

Device	Annual Operations	Daily Operations
OLTC	726	≈ 2
VReg 1A	8448	≈ 23
VReg 1B	4893	≈ 13
VReg 1C	5136	≈ 14
VReg 2A	8455	≈ 23
VReg 2B	6508	≈ 18
VReg 2C	6831	≈ 19

Use Case 2a.1: Low Penetration PV @ PF=1

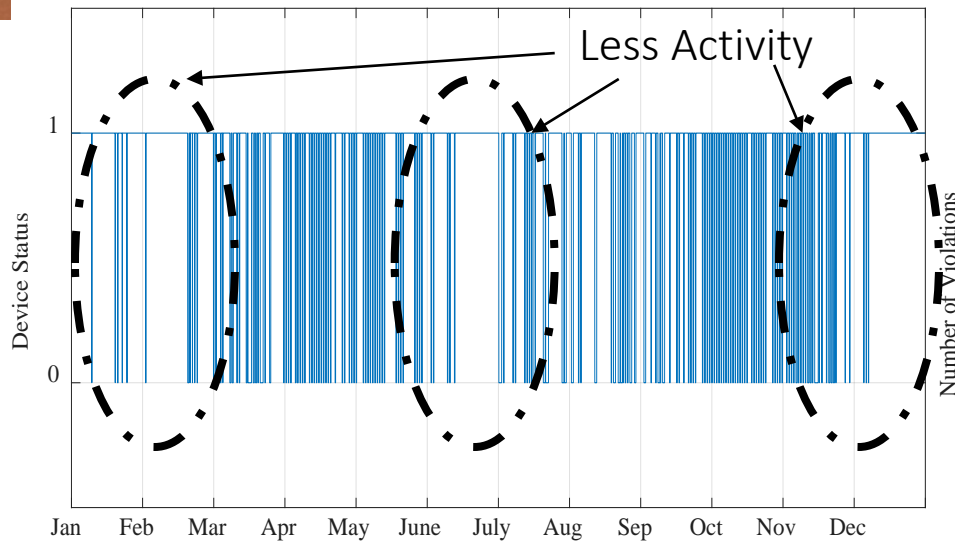

Capacitor Bank 890
Switching Profile

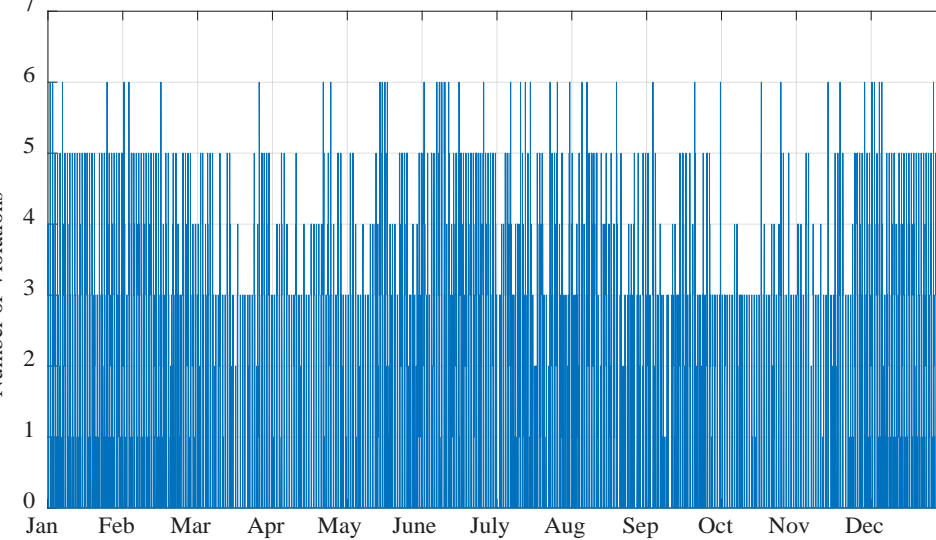

Voltage Violations

- Annual number of Capacitor Operations = 352
- No more than 6 voltage violations on a given day.
- Non-uniform Capacitor Operation.

Use Case 2a.2: Low Penetration PV @ CPF=0.95

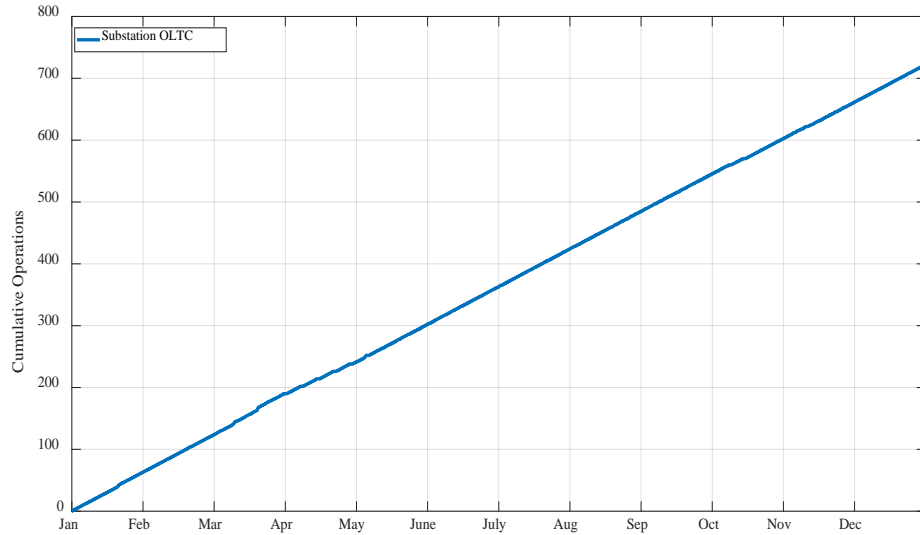

OLTC

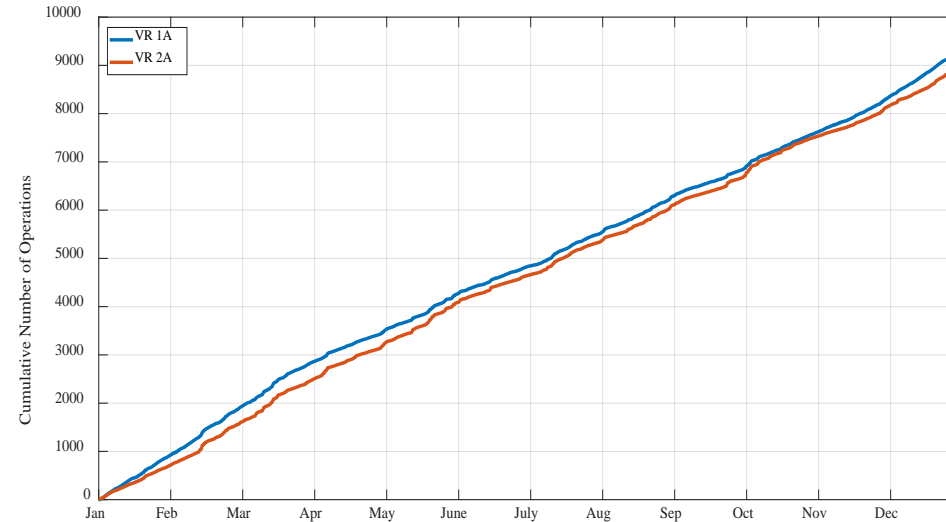

Voltage Regulators

Device	Annual Operations	Daily Operations
OLTC	722	≈ 2
VReg 1A	9380	≈ 25
VReg 1B	5401	≈ 14
VReg 1C	5566	≈ 15
VReg 2A	9073	≈ 25
VReg 2B	7340	≈ 20
VReg 2C	7689	≈ 21

Use Case 2a.2: Low Penetration PV @ CPF=0.95

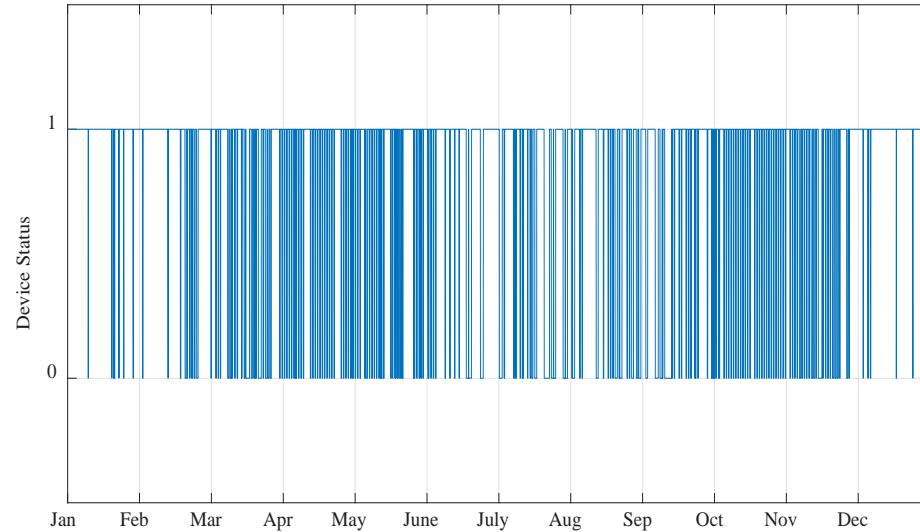

Capacitor Bank 890 Switching Profile

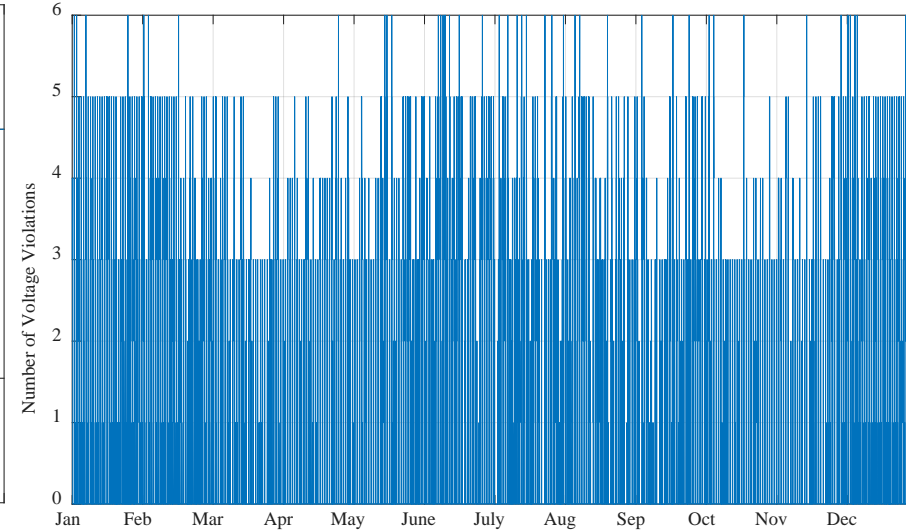

Voltage Violations

- Annual number of Capacitor Operations = 450
- Frequent voltage violations.
- Non-uniform Capacitor Operation.

Use Case 2a.3: Low Penetration PV-Volt VAR

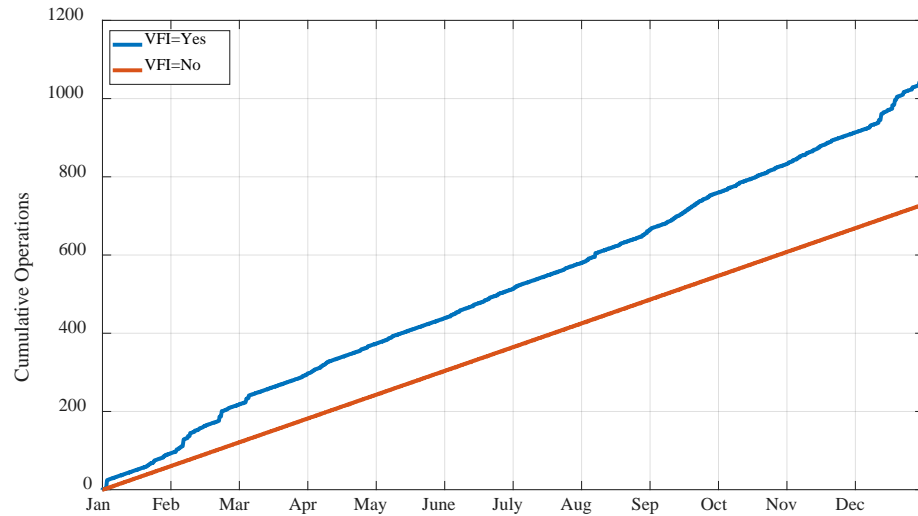

OLTC Cumulative Operations

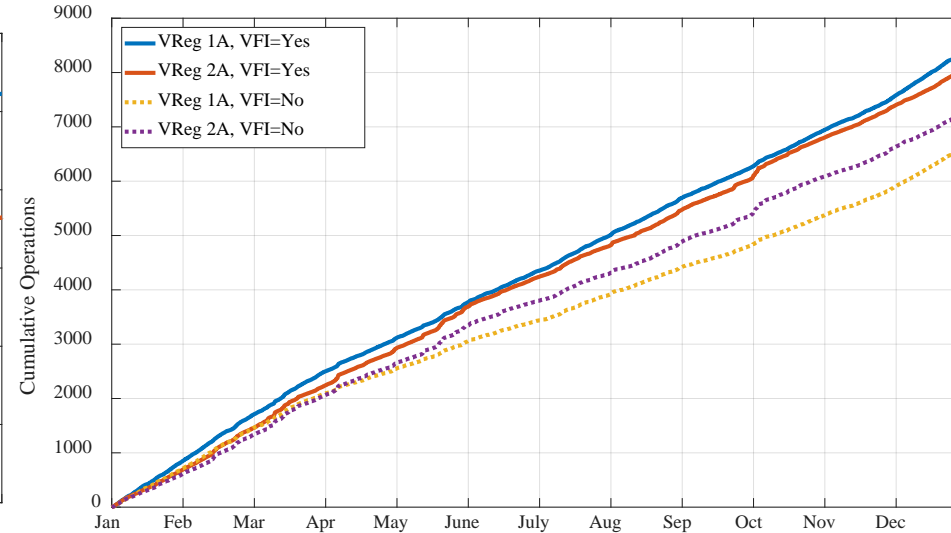

VReg Cumulative Operations

Device	Annual Operations [VFI=True]	Annual Operations [VFI=False]
OLTC	1046	730
VReg 1A	8432	6658
VReg 1B	5543	3914
VReg 1C	5436	4194
VReg 2A	8151	7356
VReg 2B	6560	5336
VReg 2C	6637	5612

Use Case 2a.3: Low Penetration PV-Volt VAR

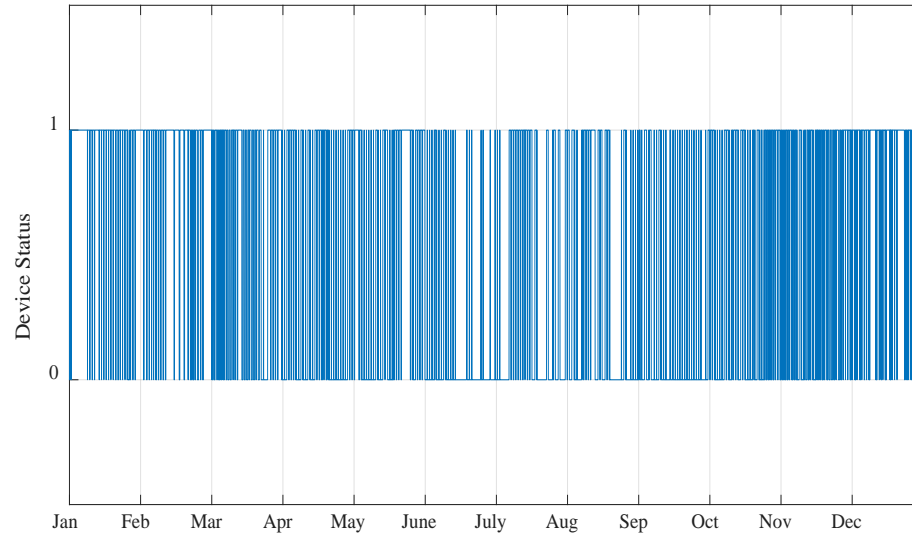

Capacitor Bank 890
Switching Profile

- Annual number of Capacitor Operations with VFI False = 718

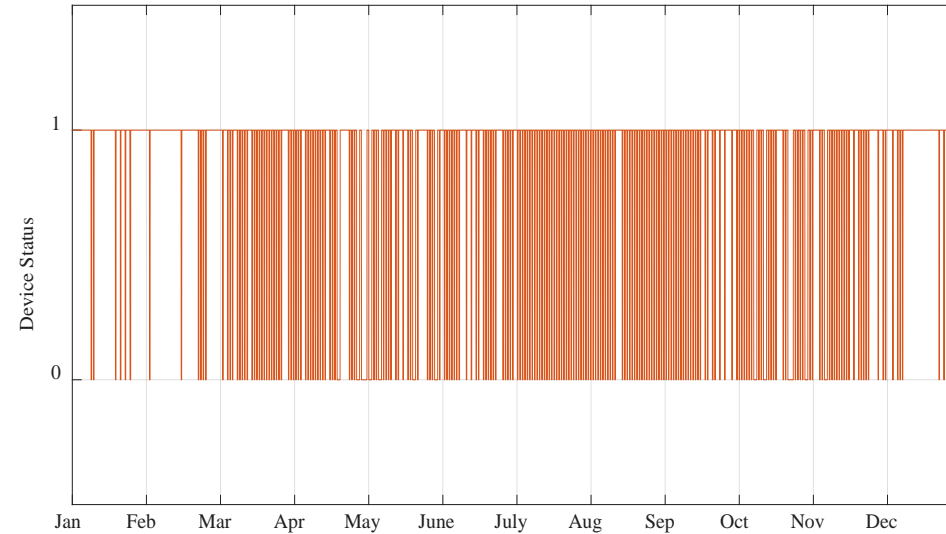

Capacitor Bank 890
Switching Profile

- Annual number of Capacitor Operations with VFI False = 468

Use Case 2b.1: High Penetration PV @ $P_{F=1}$

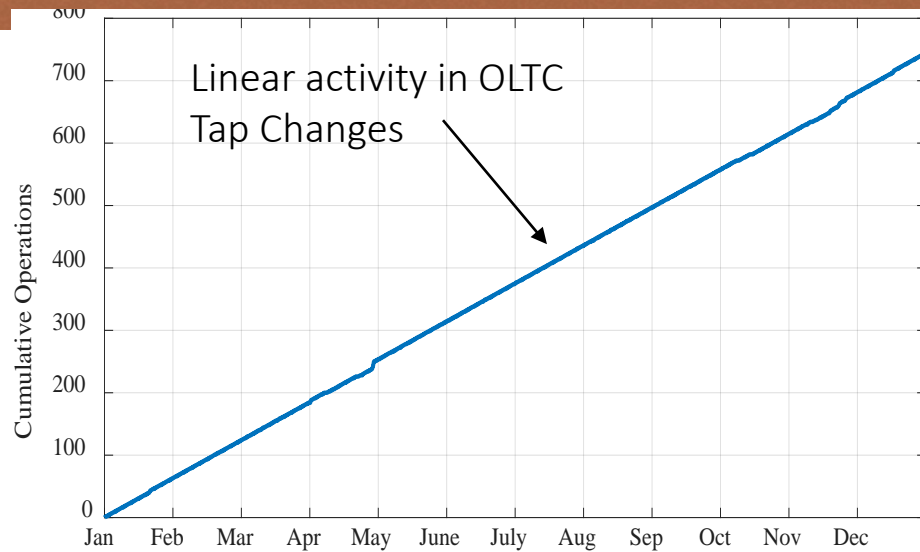

OLTC

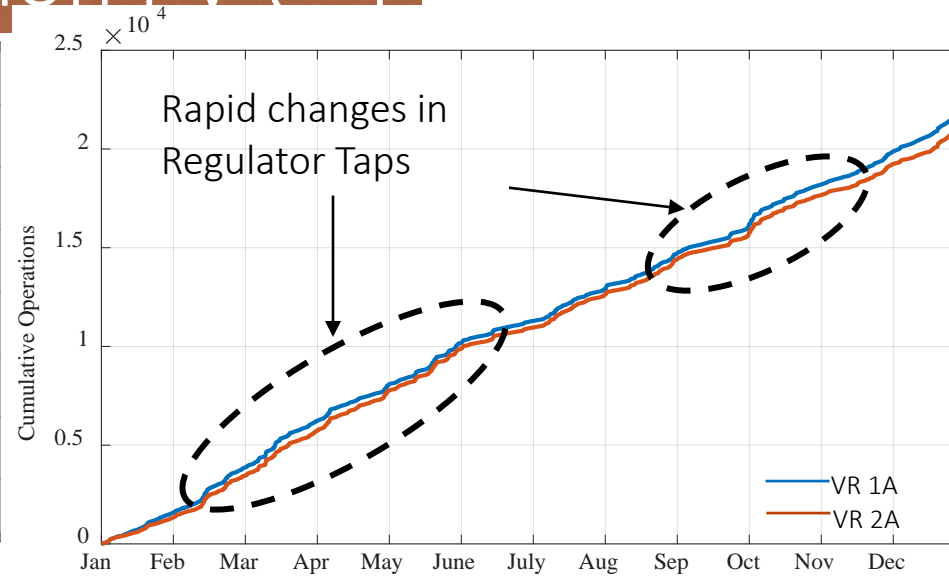

Voltage Regulators

Device	Annual Operations	Daily Operations
OLTC	744	≈ 2
VReg 1A	22054	≈ 61
VReg 1B	10129	≈ 28
VReg 1C	11378	≈ 32
VReg 2A	21321	≈ 59
VReg 2B	16450	≈ 45
VReg 2C	17193	≈ 47

Use Case 2b.1: High Penetration PV @ $P_{F=1}$

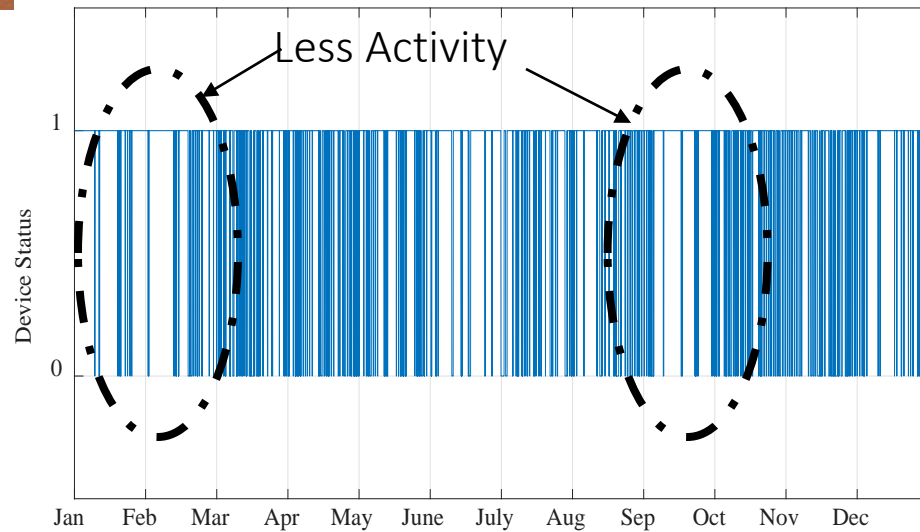

Capacitor Bank 890 Switching Profile

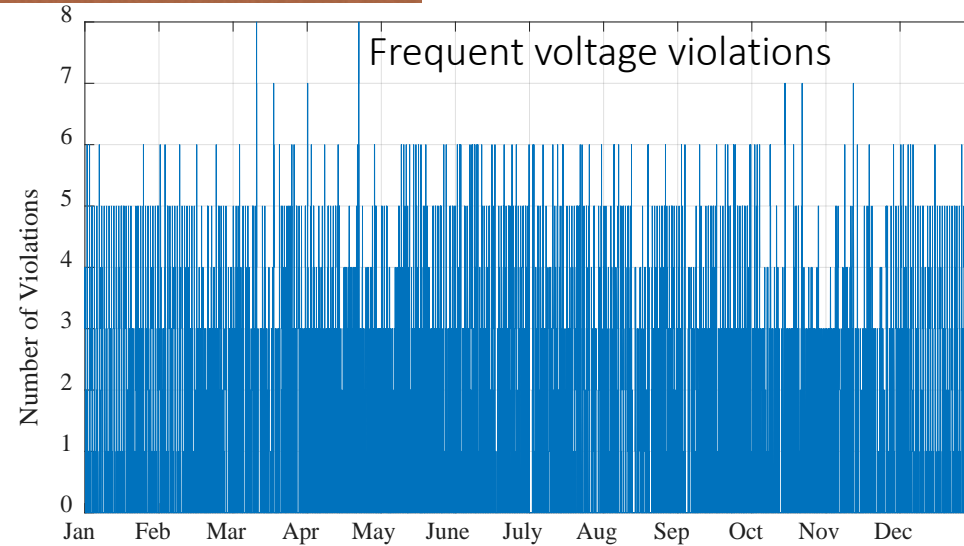

Voltage Violations

- Annual number of Capacitor Operations = 1798
- Increase in the frequency of voltage violations.
- Non-uniform Capacitor Operation.

Use Case 2b.2: High Penetration PV, CPF=0.95

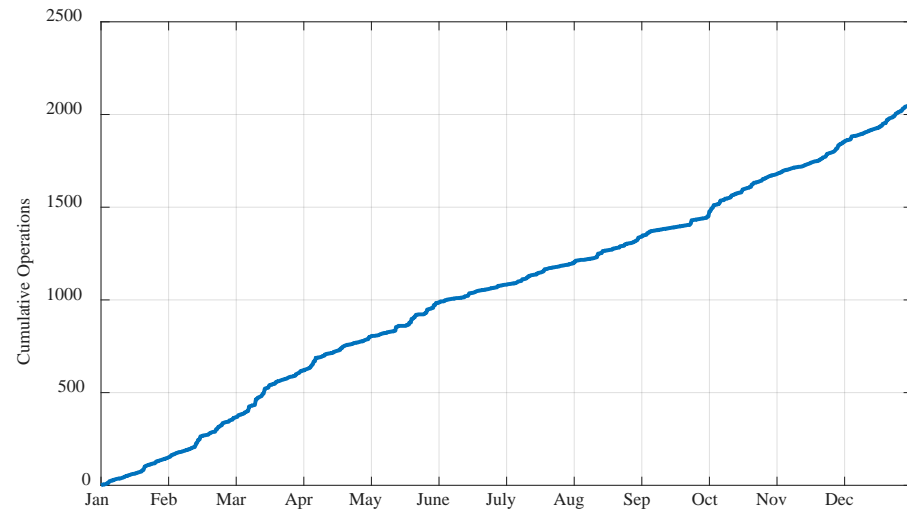

OLTC

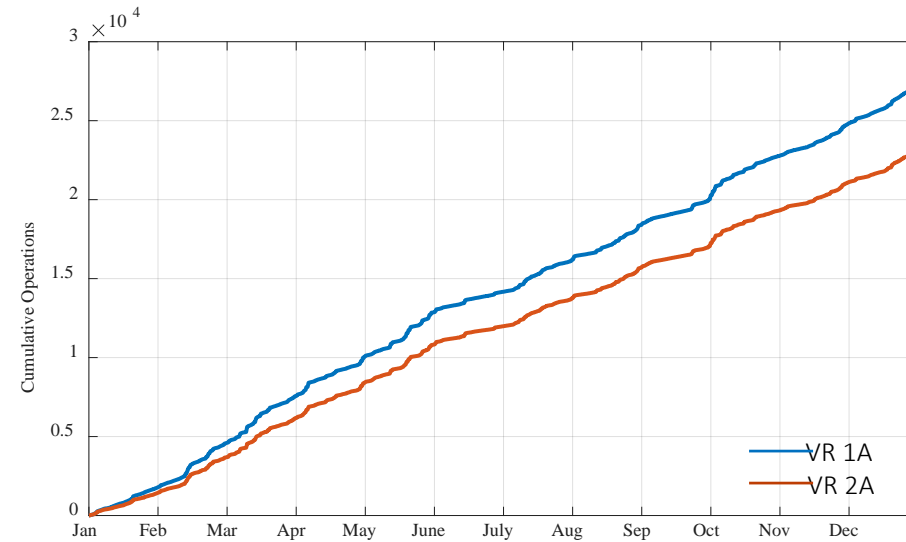

Voltage Regulators

Device	Annual Operations	Daily Operations
OLTC	2080	≈ 6
VReg 1A	27422	≈ 75
VReg 1B	13765	≈ 38
VReg 1C	14670	≈ 41
VReg 2A	23237	≈ 64
VReg 2B	20048	≈ 59
VReg 2C	20629	≈ 57

Use Case 2b.2: High Penetration PV, CPF=0.95

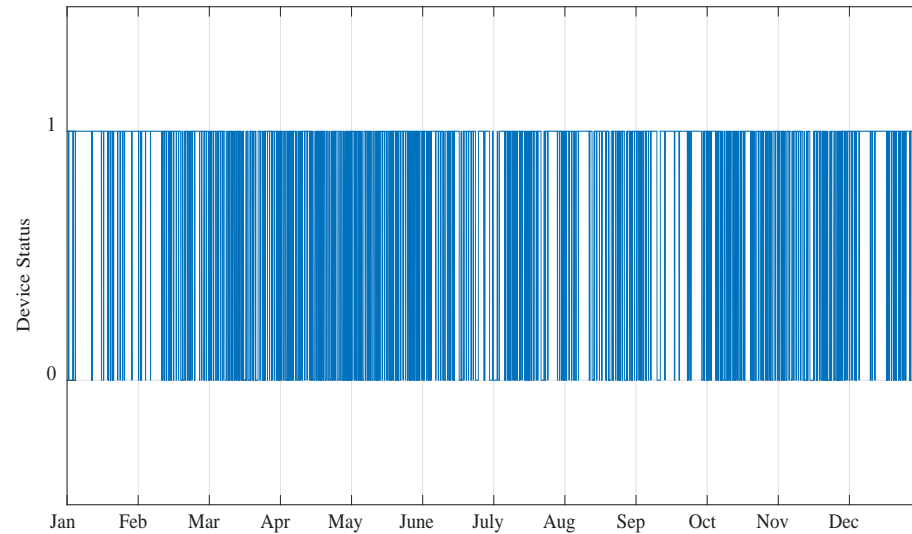

Capacitor Bank 890
Switching Profile

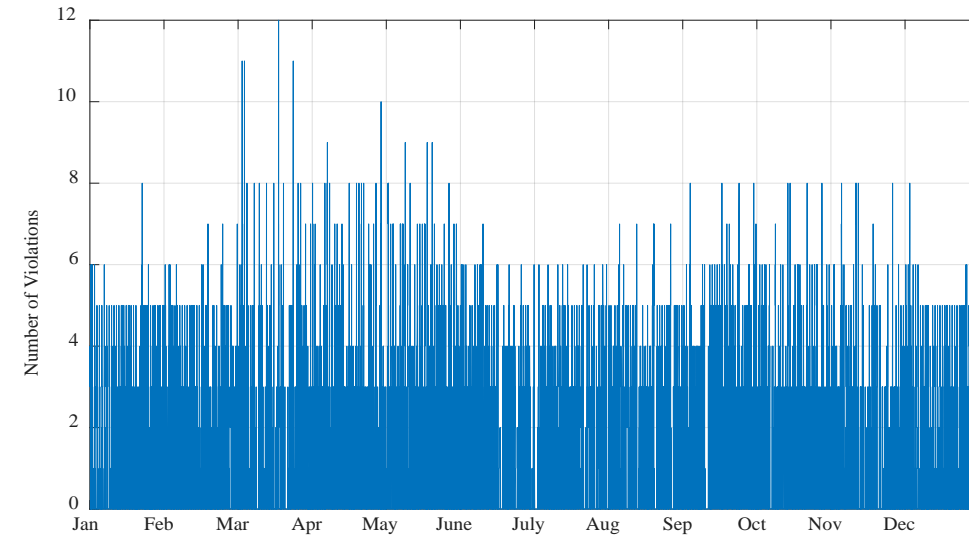

Voltage Violations

- Annual number of Capacitor Operations = 2556
- Increase in the frequency of voltage violations.
- Non-uniform Capacitor Operation.

Use Case 2b.3: High Penetration PV-Volt VAR

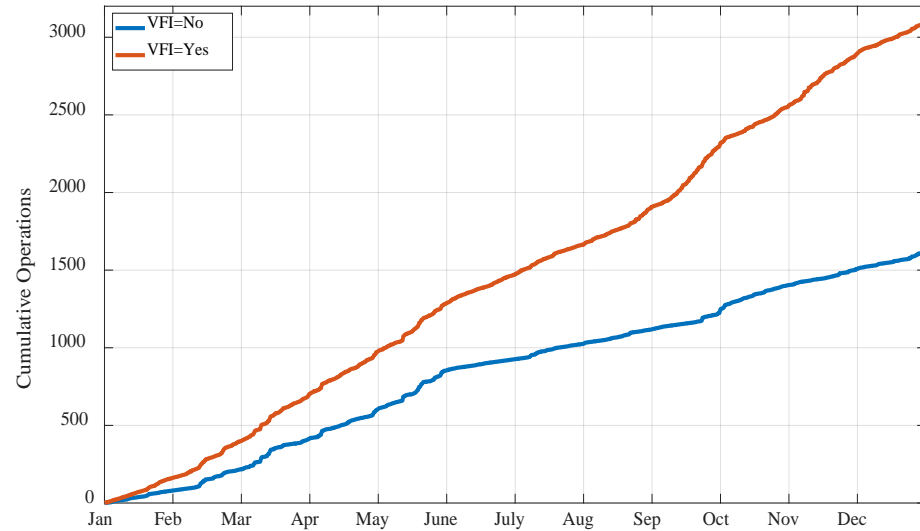

OLTC

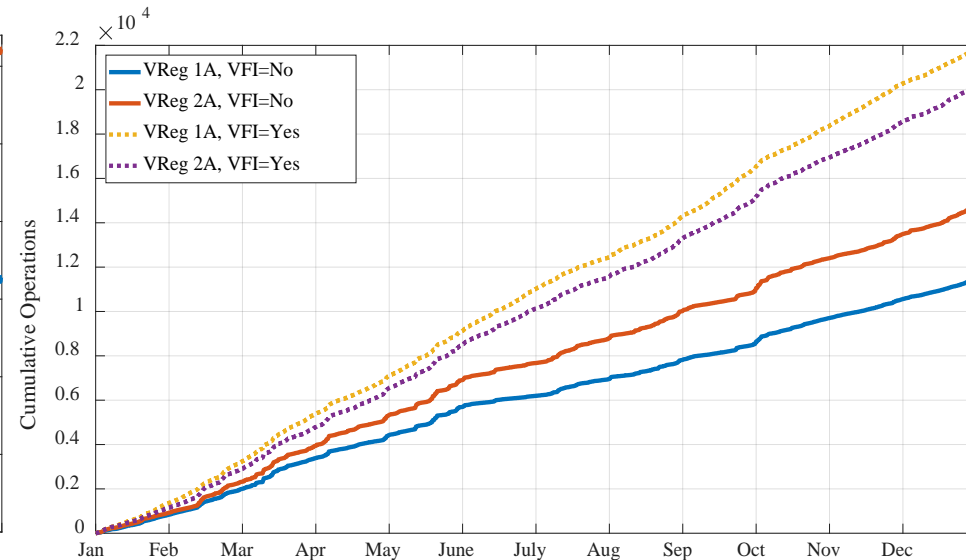

Voltage Regulators

Device	Annual Operations [VFI=True]	Annual Operations [VFI=False]
OLTC	812	736
VReg 1A	19341	11516
VReg 1B	11273	4957
VReg 1C	10559	6784
VReg 2A	18142	14987
VReg 2B	15936	10175
VReg 2C	15698	10465

Use Case 2b.3: High Penetration PV-Volt VAR

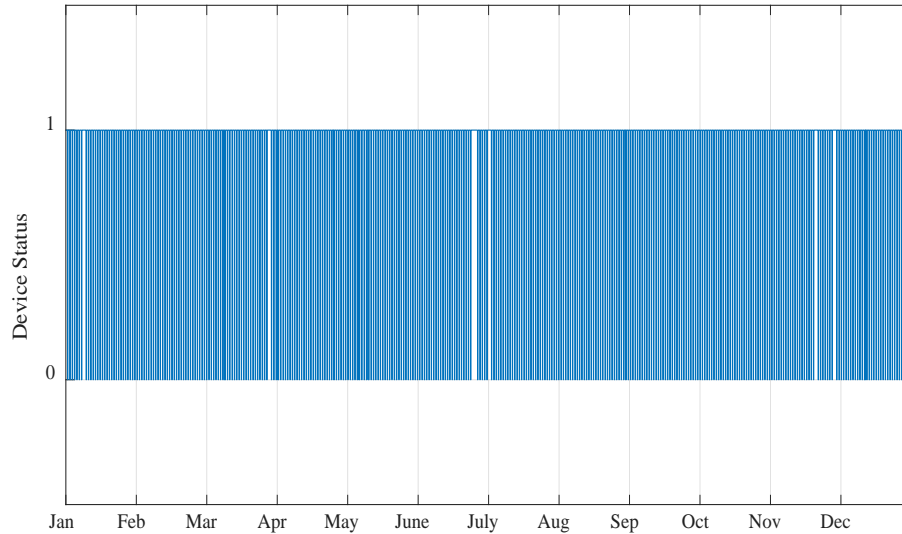

Capacitor Bank 890 Switching Profile, VFI=No

- Annual number of Capacitor Operations with VFI False = 736

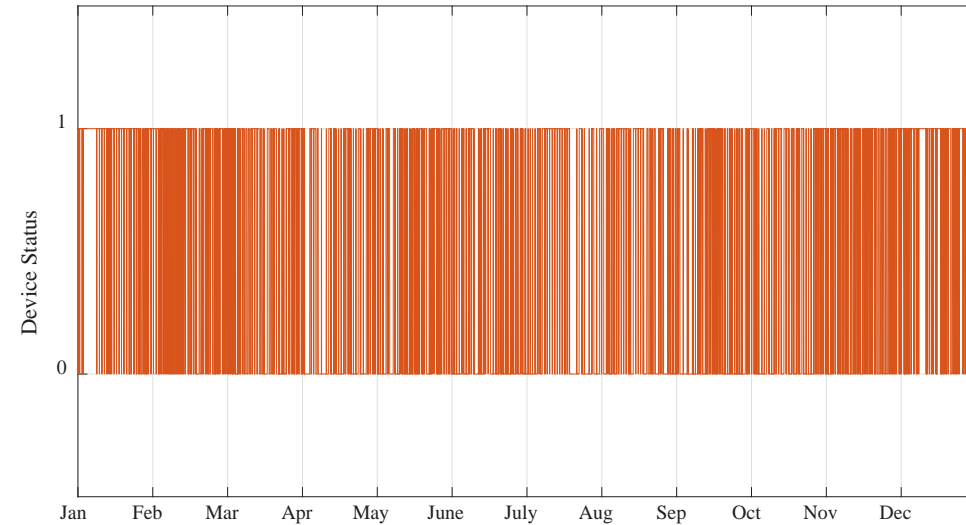

Capacitor Bank 890 Switching Profile, VFI=Yes

- Annual number of Capacitor Operations with VFI True = 812

Use Case 2b.3: High Penetration PV-Volt VAR

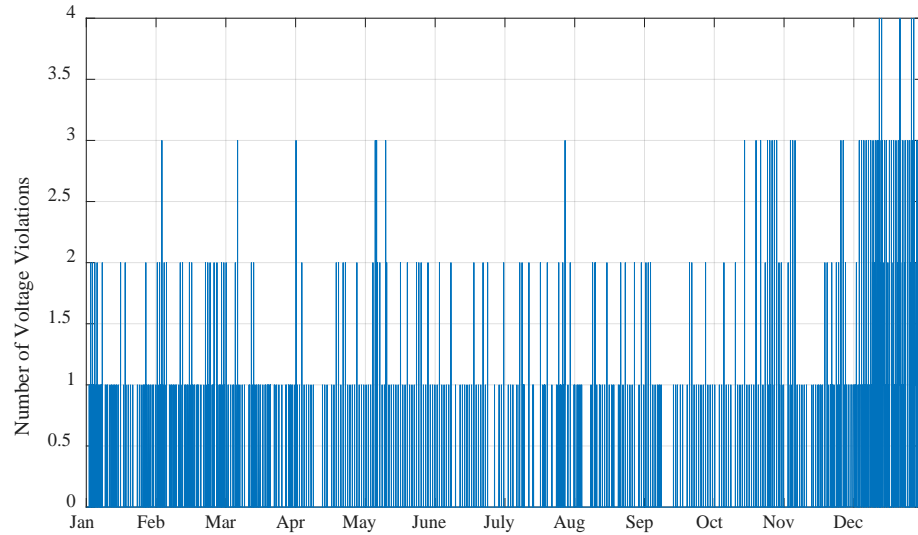

Voltage Violations, VFI=
No

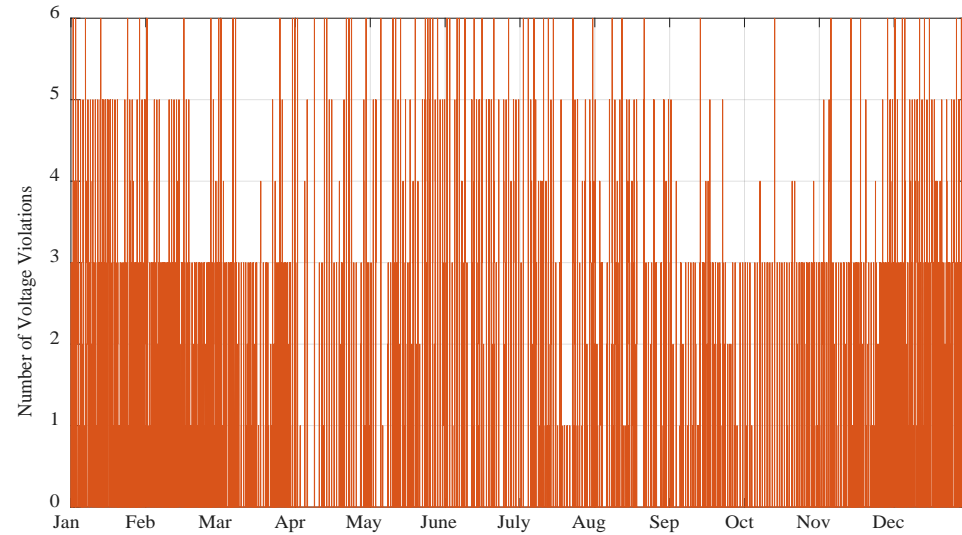

Voltage Violations, VFI=
Yes

Impact on Tap Changing Devices

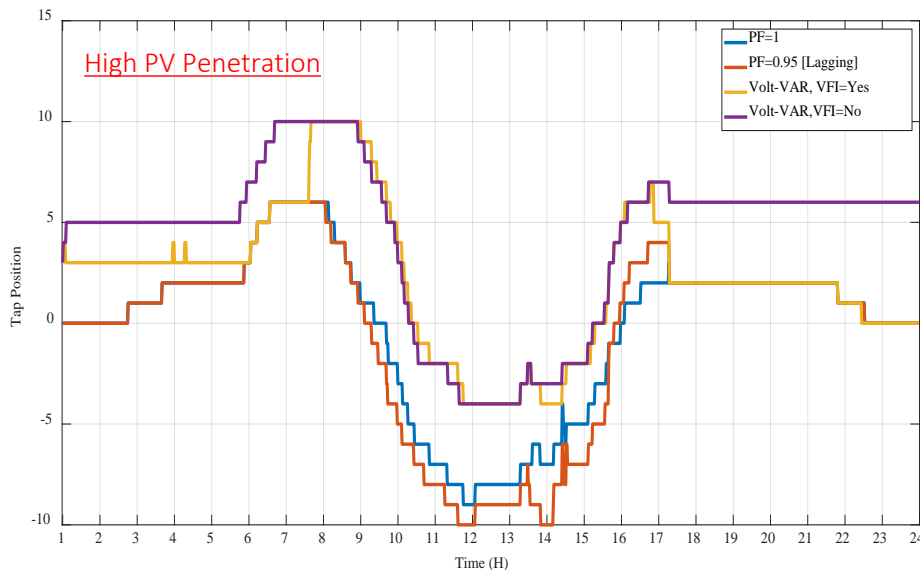
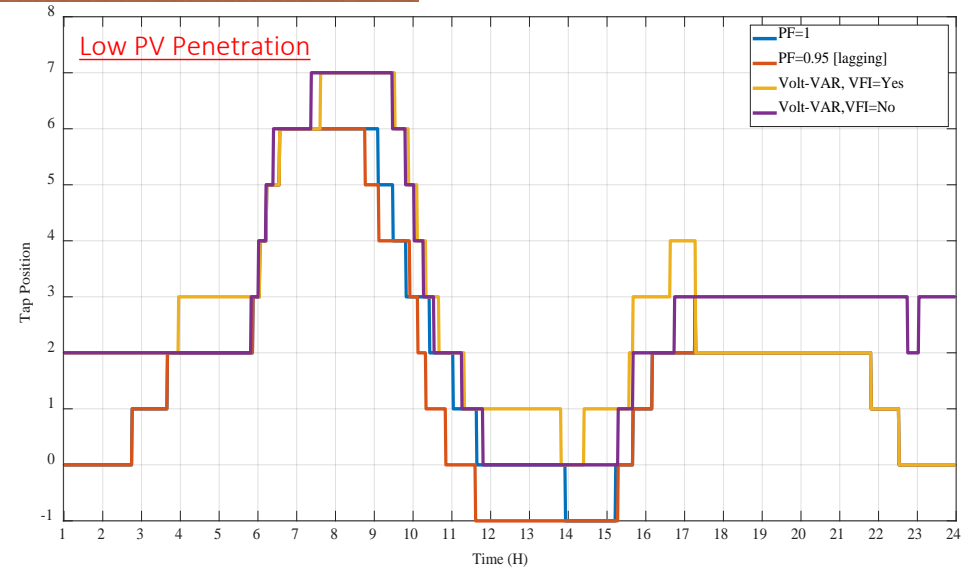
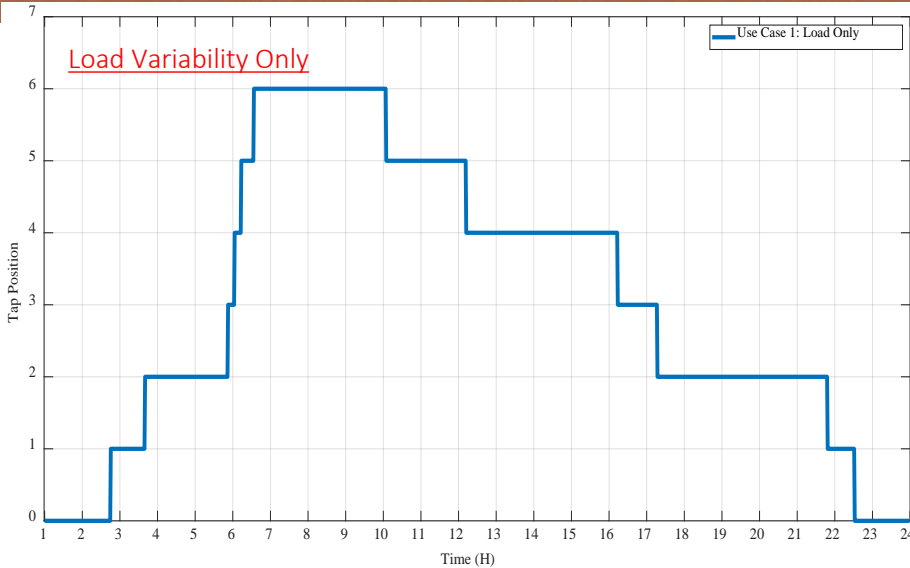

- High PV Penetration causes rapid voltage fluctuations and hence increases the stress on the Tap Changing Devices.
- Difficult to control voltage variations.
- Increase in the number of Operations.

Impact on Tap Changing Devices

Device	Load Only	Low PV, PF=1	Low PV, PF=0.95	Low PV, Volt-VAR [VFI=Yes]	Low PV, Volt-VAR [VFI=No]	High PV, PF=1	High PV, PF=0.95	High PV, Volt-VAR [VFI=Yes]	High PV, Volt-VAR [VFI=No]
OLTC	730	726	722	1046	730	744	2080	812	736
VReg 1A	7290	8448	9380	8432	6658	22054	27422	19341	11516
VReg 1B	4795	4893	5401	5543	3914	10129	13765	11273	4957
VReg 1C	5140	5136	5566	5436	4194	11378	14670	10559	6784
VReg 2A	5143	8455	9073	8151	7356	21321	23237	18142	14987
VReg 2B	4750	6508	7340	6560	5336	16450	20048	15936	10175
VReg 2C	5055	6831	7689	6637	5612	17193	20629	15698	10465
Cap. 890	604	352	450	718	468	1798	2556	736	812

Solution to the problem:
A Continuous VAR Support
System

Distribution level RPC- Challenges

- **Economics!**
 - While justifiable at transmission levels, RPC becomes cost-prohibitive at distribution voltage level.
 - Exponential rise in the capital cost.
- **Reliability!**
 - Electrolytic capacitors have well-known failure modes.
 - Weakest link in the chain of reliability.

Distribution level RPC- Solutions

- **Economics!**
 - Lowering the cost of the Power Quality Compensator.
 - Capable of executing multiple functions simultaneously, e.g. VAR compensation and harmonic filtering.
- **Reliability!**
 - Getting rid of electrolytic capacitors.
 - New technology for energy storage.

D-STATCOM System: Theoretical Assessment

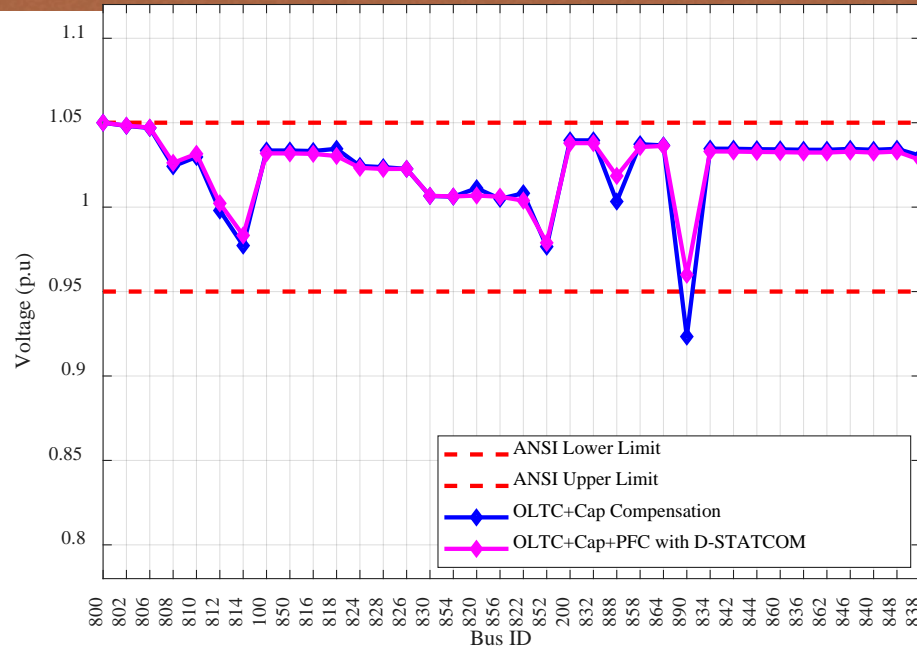

Power Factor Correction @ Bus 890
(VAR Compensation)

Modes of Operation

1) Power Factor Correction (PFC):

- D-STATCOM regulates the power factor at the bus.
- In these examples, the power factor of Bus 890 was corrected to 1.0 from a previous value of 0.89.

$$Q_{C,i} = -Q_{L,i} ; i \in \{a, b, c\}$$

$$\bar{I}_{C,i} = \frac{S_{C,i}}{\bar{V}_{L,i}^*} = \frac{-j \left(S_{L,i} \sqrt{1 - PF_i^2} \right)}{\bar{V}_{L,i}^*}$$

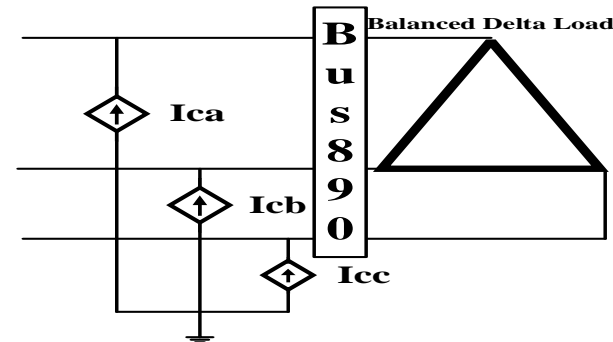

D-STATCOM System: Theoretical Assessment

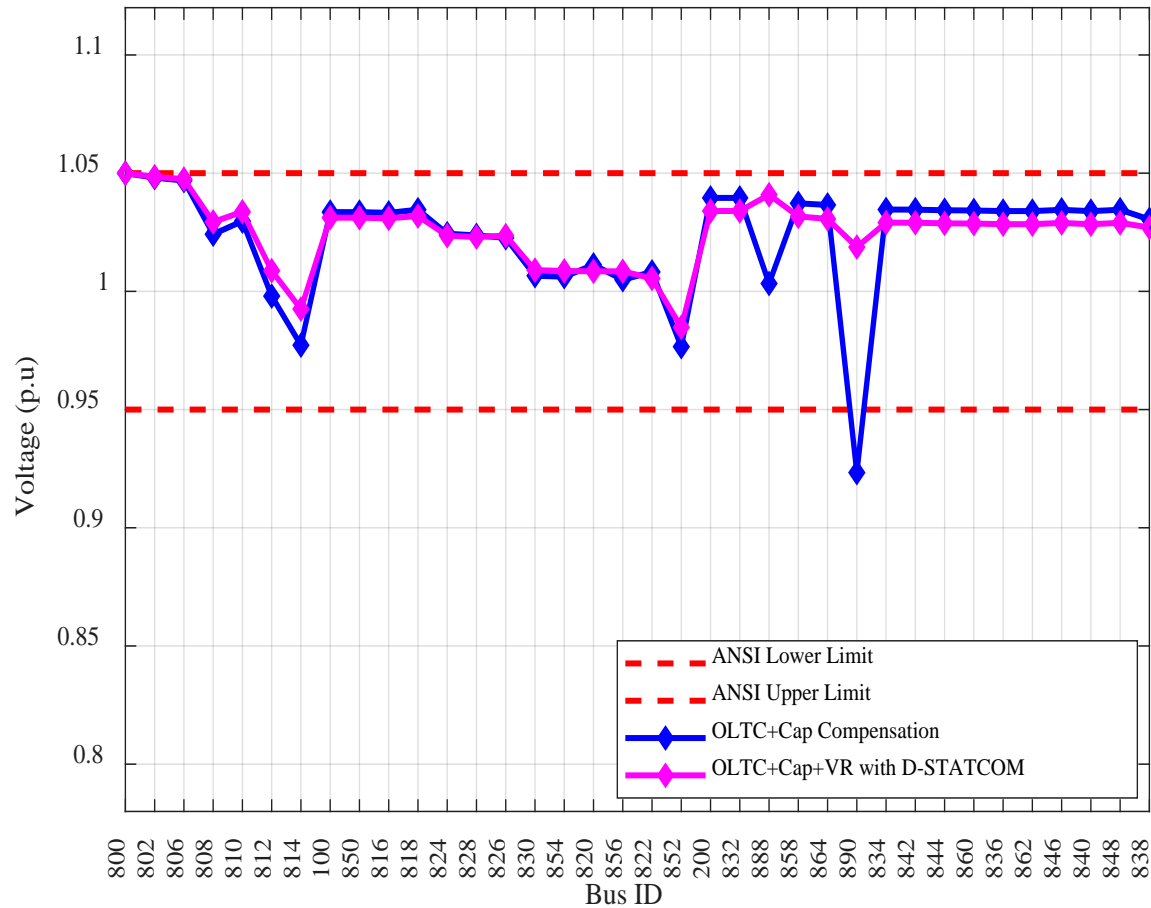

Voltage Regulation @ Bus 890
Upstream Voltage Drop Compensation

Modes of Operation

2) Voltage Regulation (VR): Upstream Voltage Drop Compensation:

- D-STATCOM attempts to compensate the drop in voltage from the nearest upstream neighbor.
- This entails solving a set of strongly coupled non-linear equations. It can be simplified by ignoring the effects of mutual impedance.

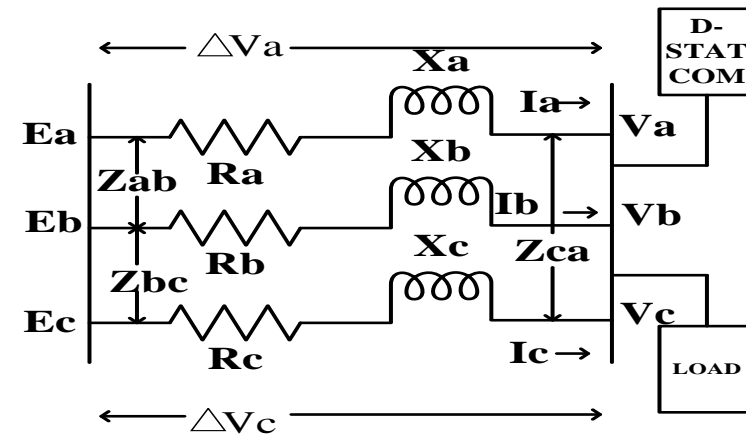

D-STATCOM System: Theoretical Assessment

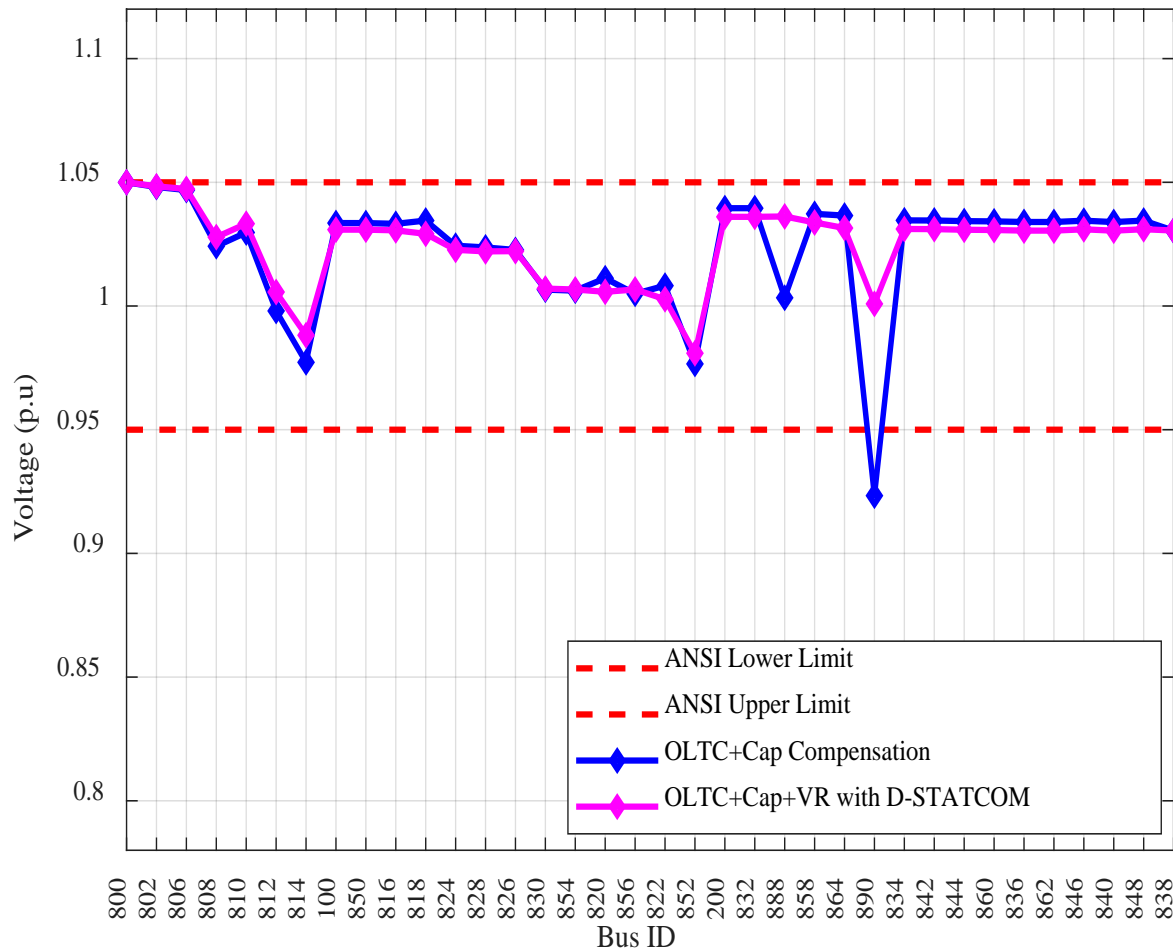

Voltage Regulation @ Bus 890
Voltage Set Point Compensation

Modes of Operation

3) Voltage Regulation (VR): Voltage Set Point:

- D-STATCOM regulates the bus voltage at a specified value.
- Value can be given by system operator

$$V_{set\ point} = 1.0\ p.u \quad [\text{Bus } 890]$$

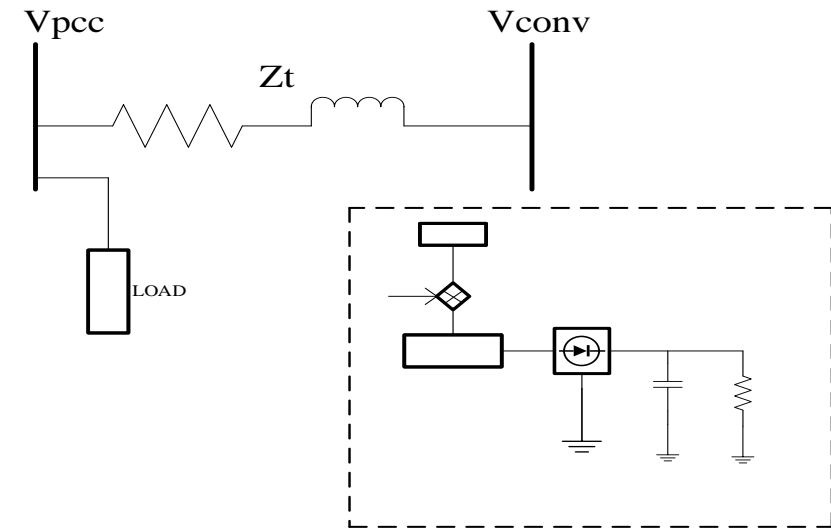

D-STATCOM System: Theoretical Assessment

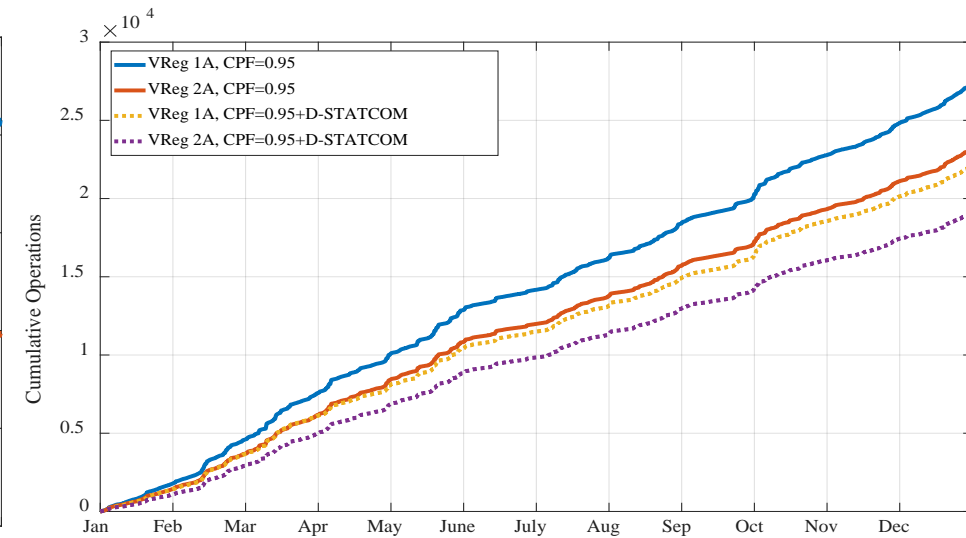
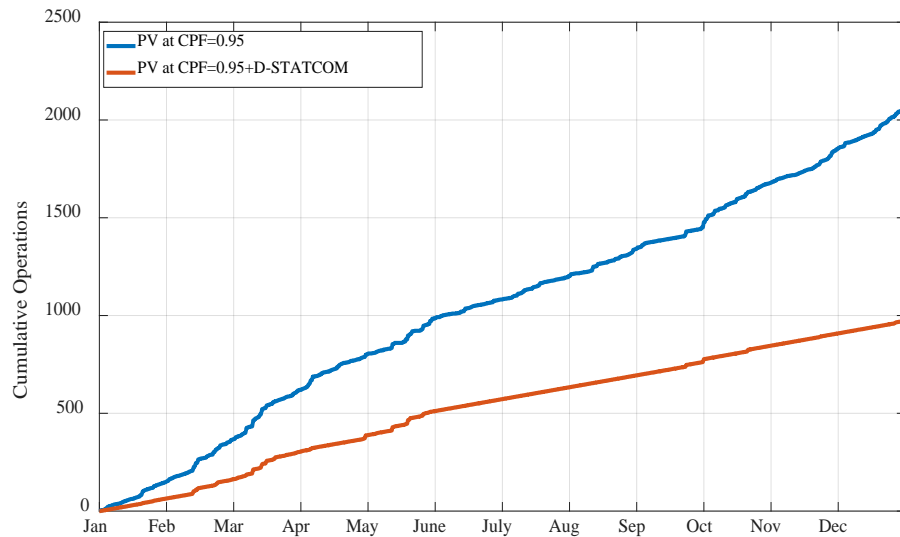
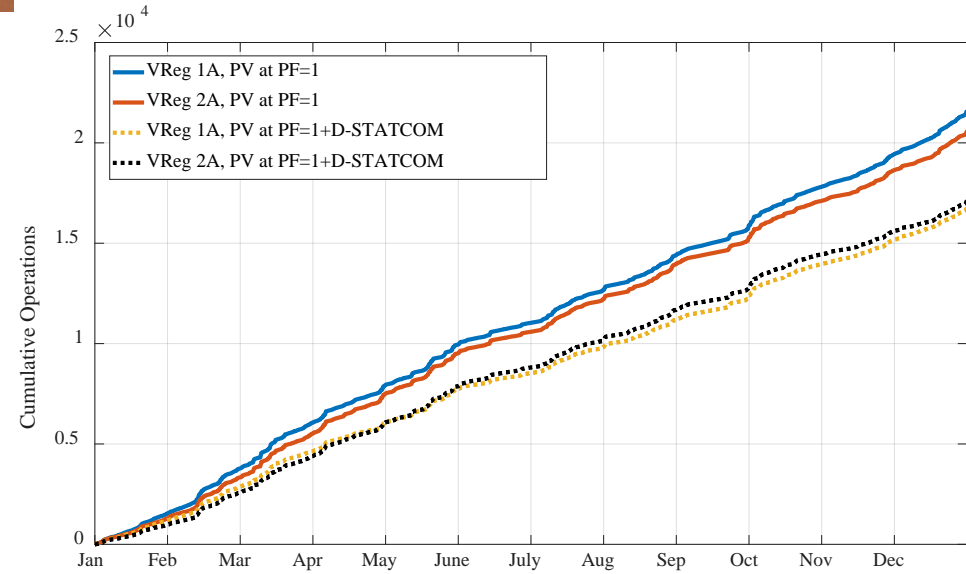
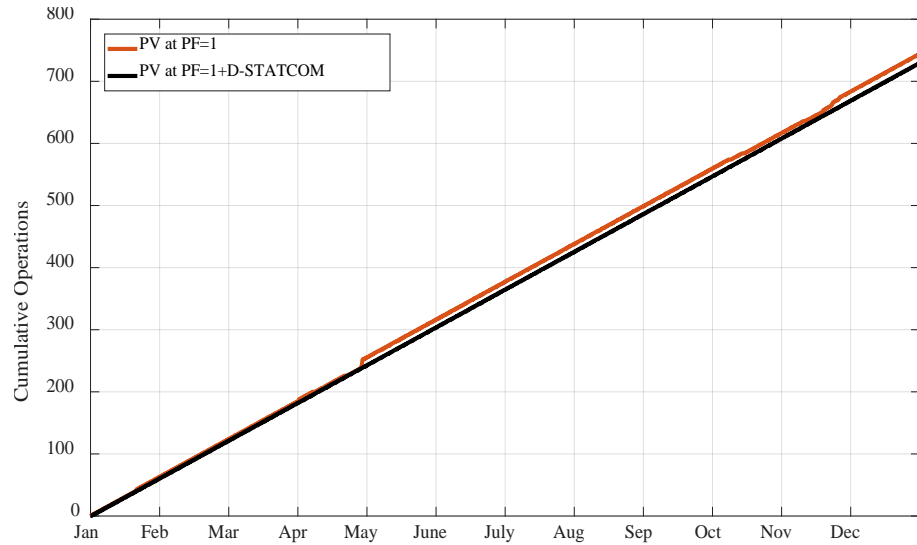

D-STATCOM System: Harmonic Control

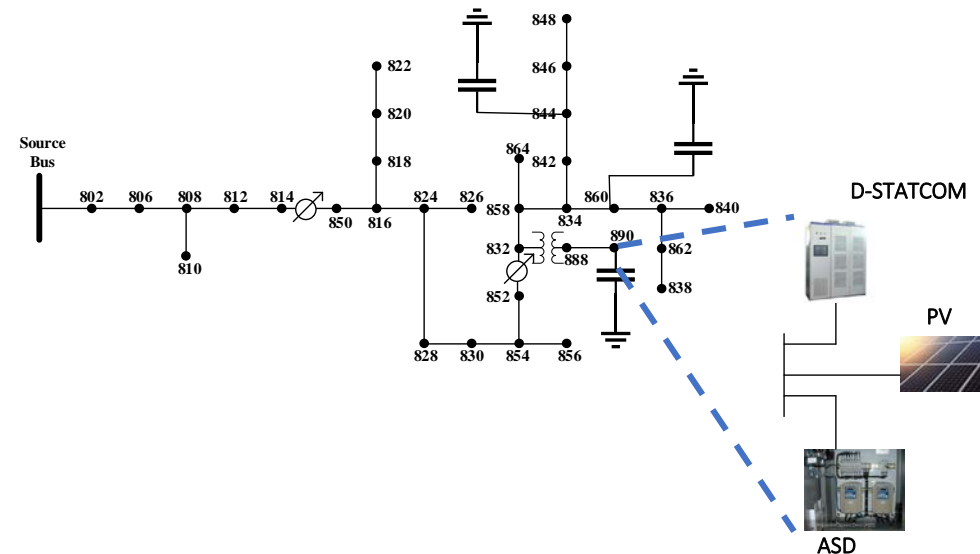
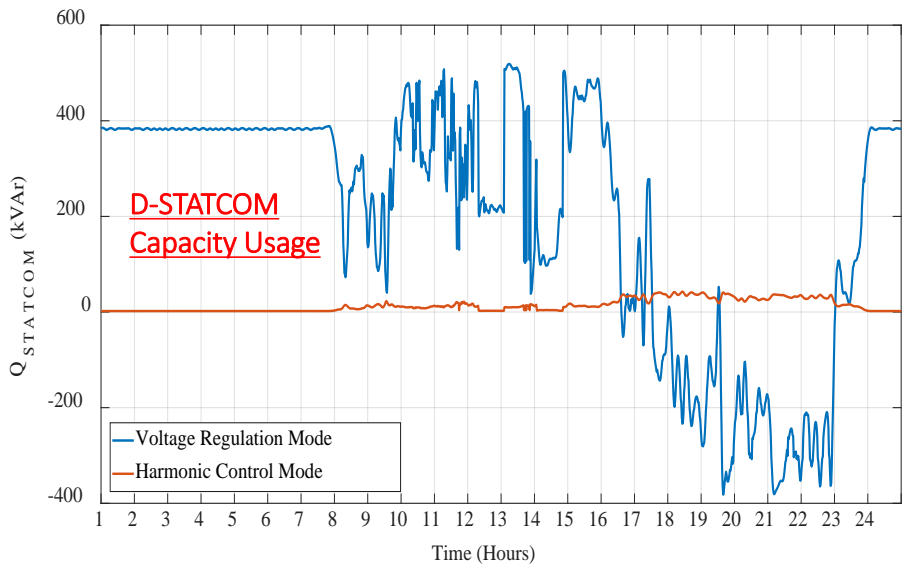
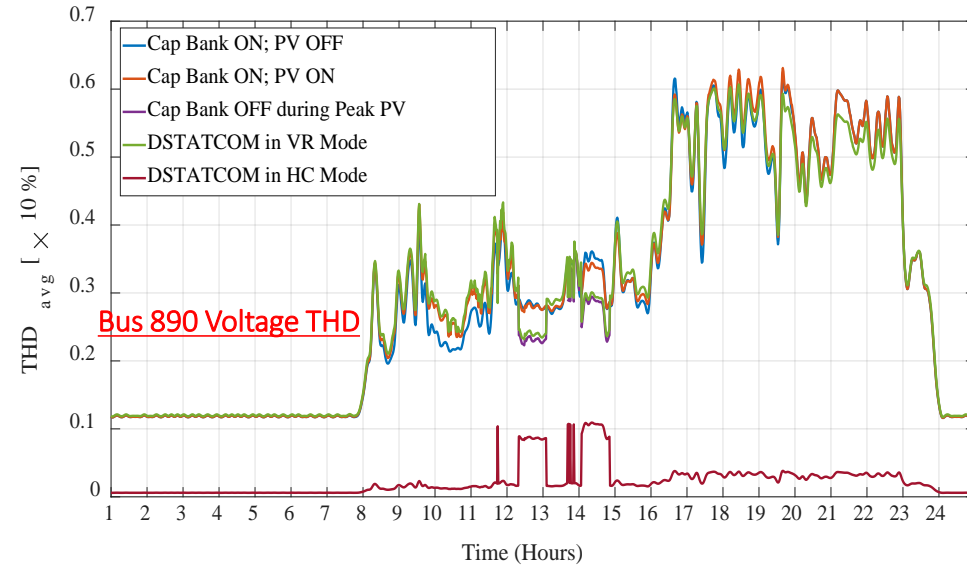
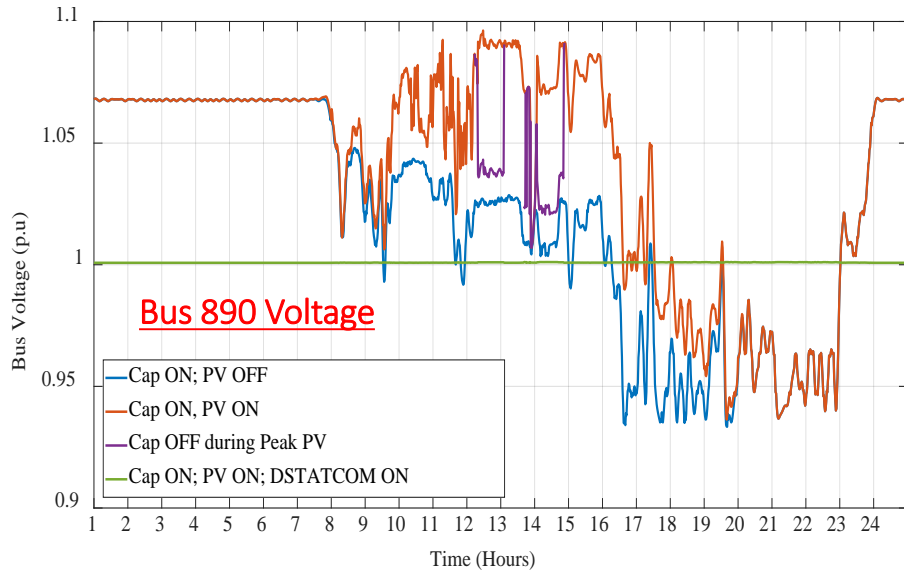

D-STATCOM system

GOAL: Fix power quality problems at their source within the distribution network with a power quality compensator (PQC) that lasts 30+ years in austere environment.

- Shunt-connected active filter
- No electrolytic capacitors
- Flexible controls

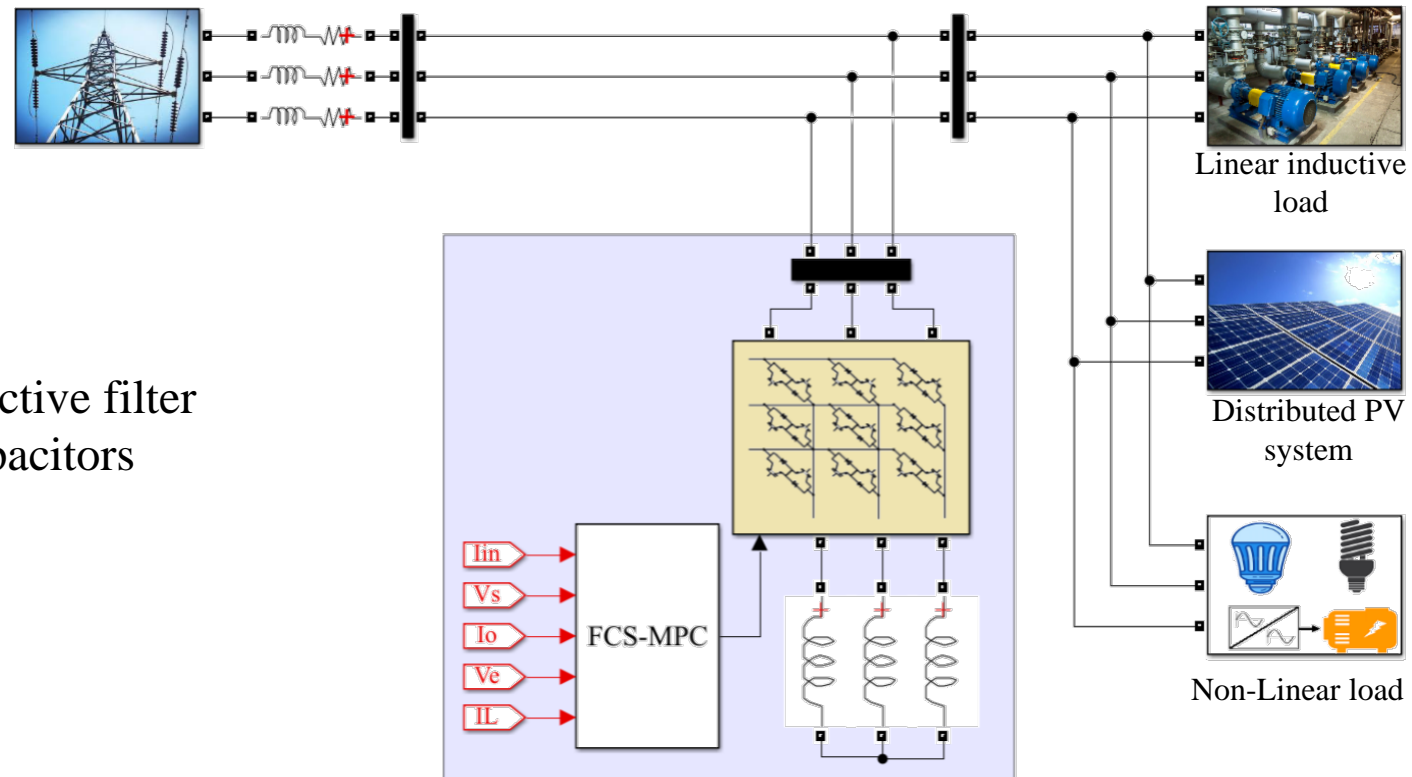

Testbed: Reactive Power

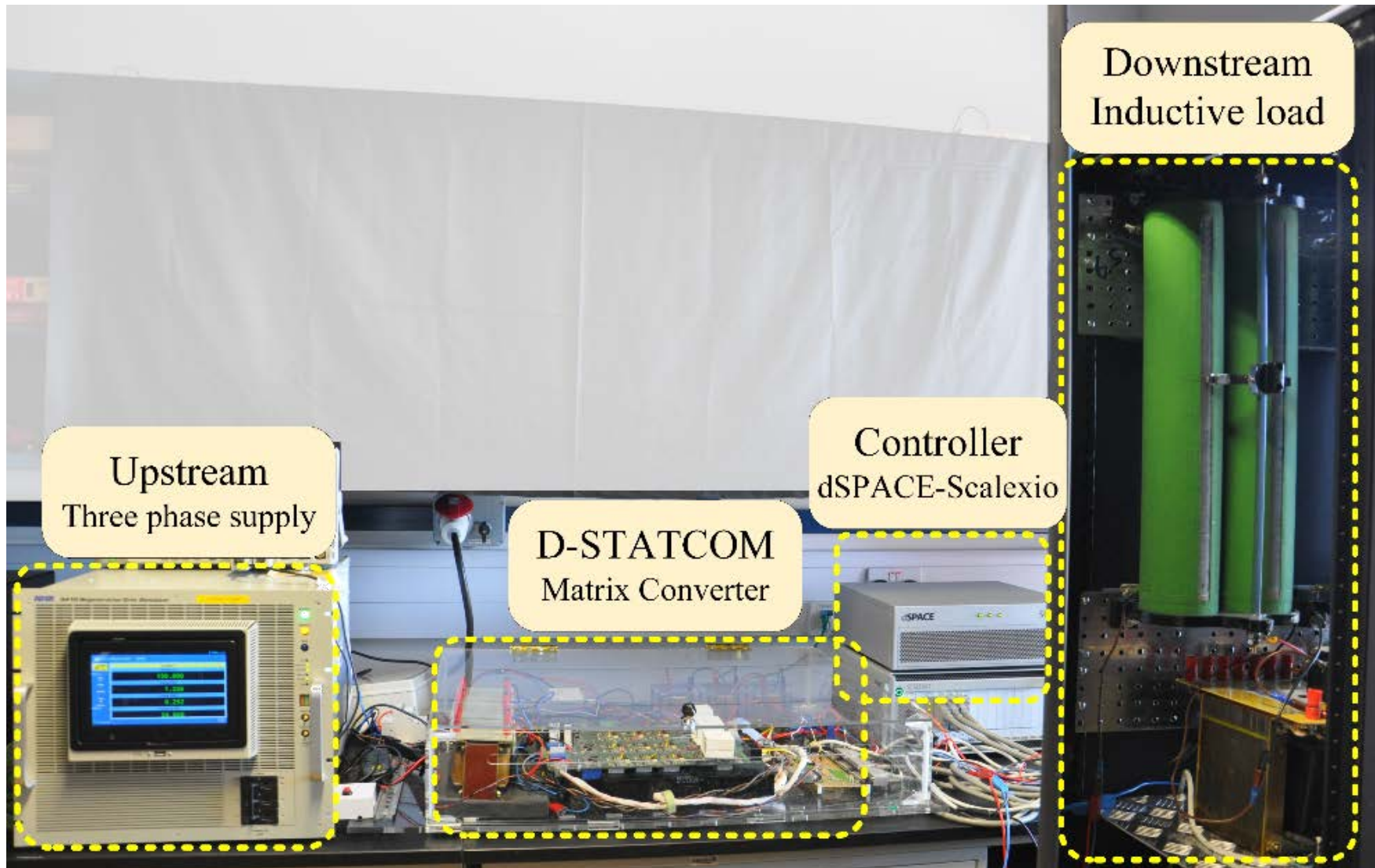

D-STATCOM System: Experimental Results

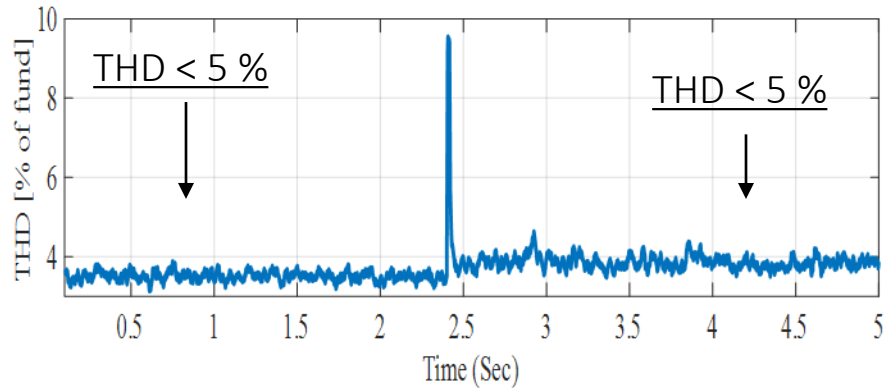
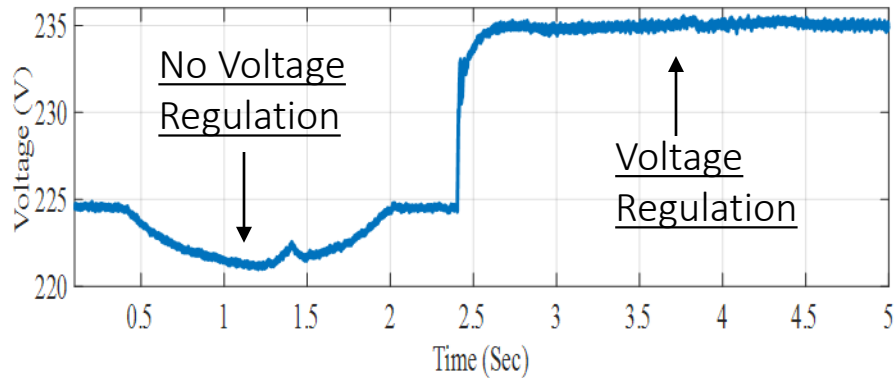

Voltage Regulation and Harmonic Control

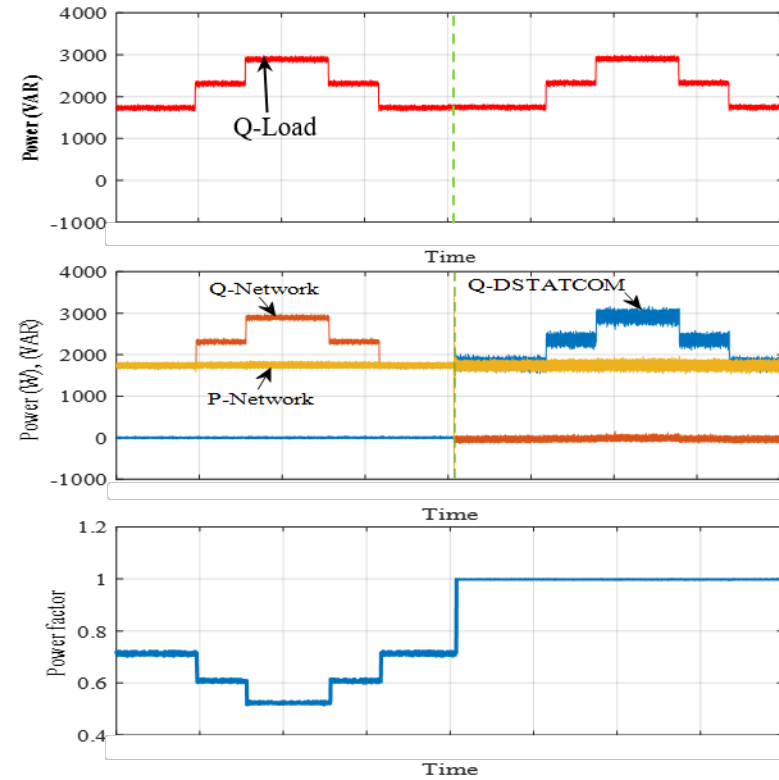

Power Factor Correction

D-STATCOM System: Experimental Results

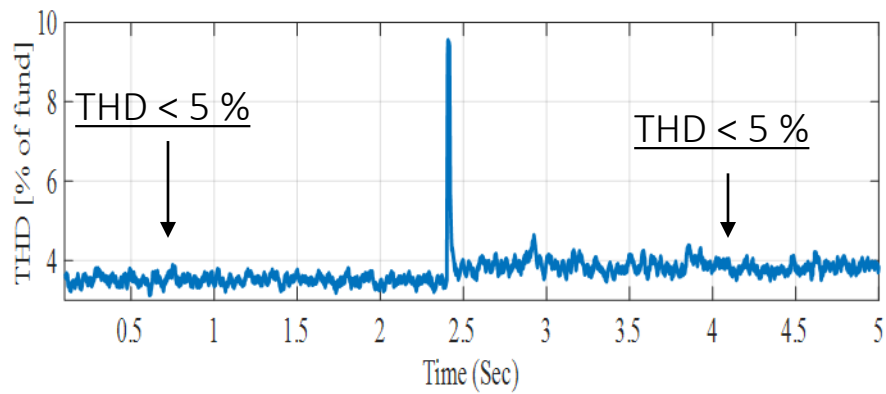
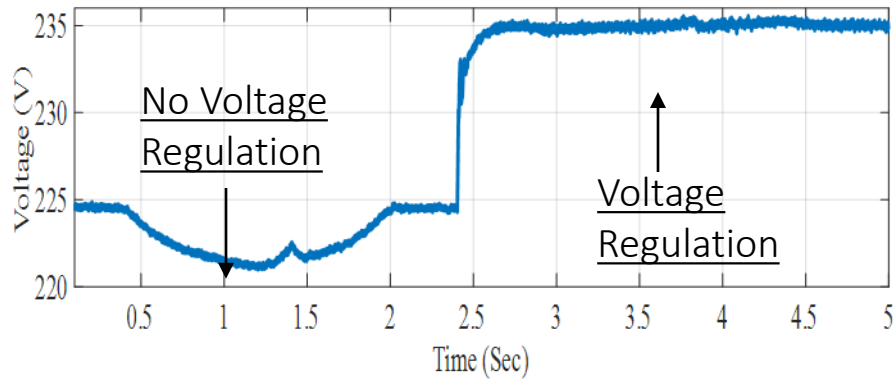

PARAMETER	VALUE
Voltage, $V_{LN,rms}$	240 V
Frequency	50Hz
Reactive Power Q (3-ph)	1,850 VAR
Active power P (3-ph)	1,700 W
Power Factor p.f	0.71
Output chokes inductance L_{MC}	36mH
Sampling time T_s	25 μ s

Distribution Asset Management: Preventive Cable Replacement

Mechanism of Failures in Cables

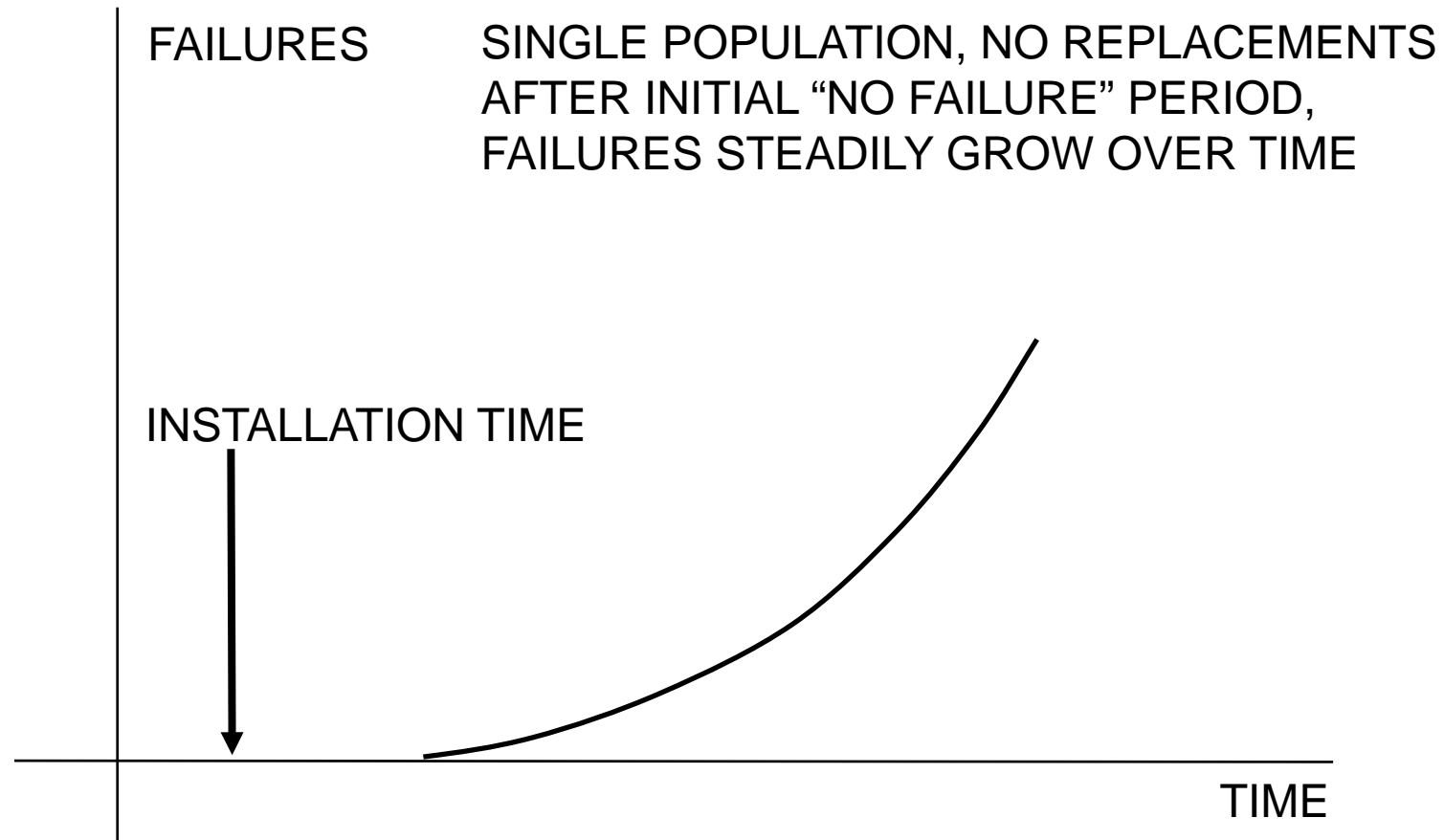

Effect of Replacements on Failure Rates

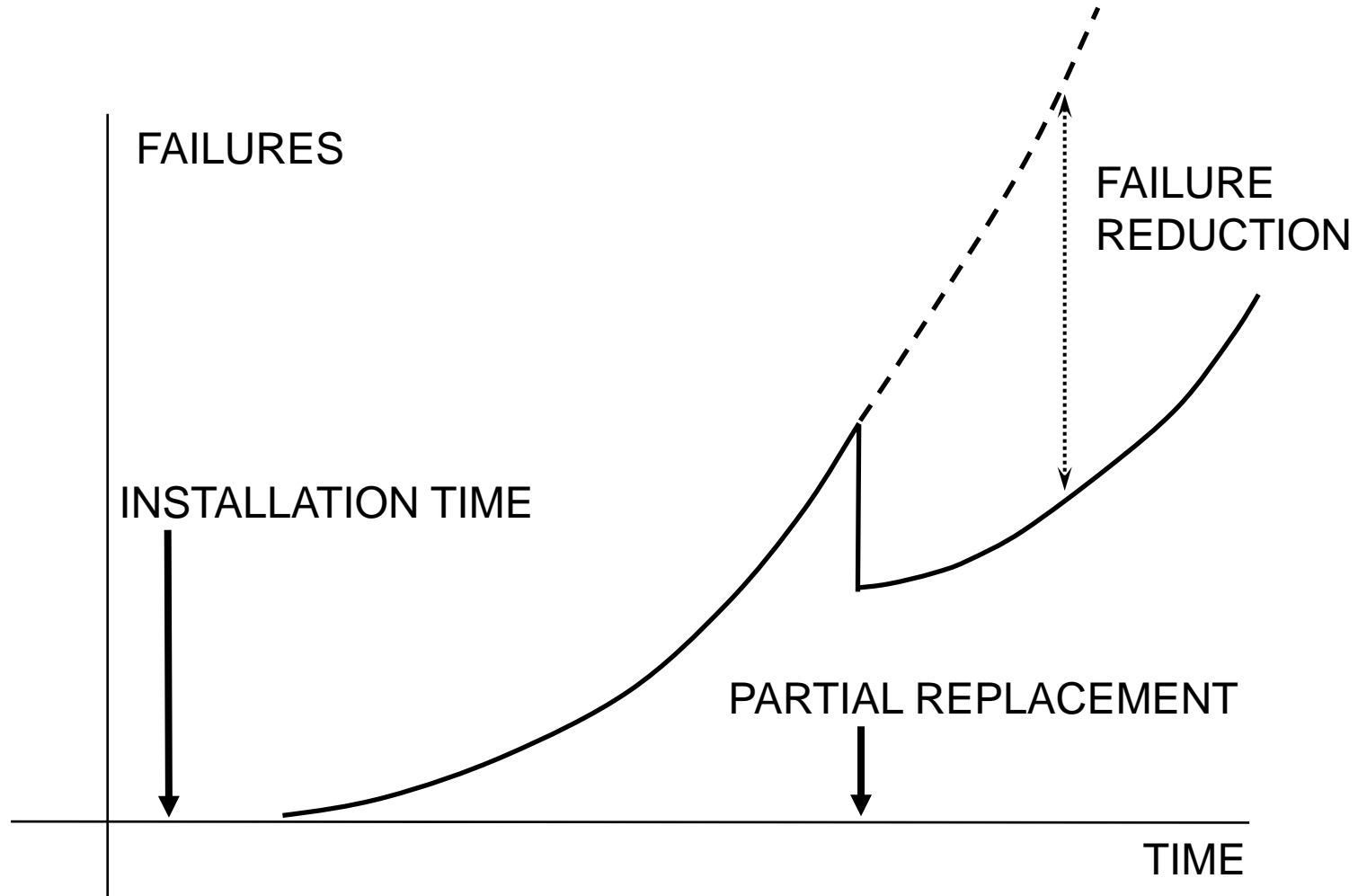

Estimation and Control of Failures in Composite Populations of Cab

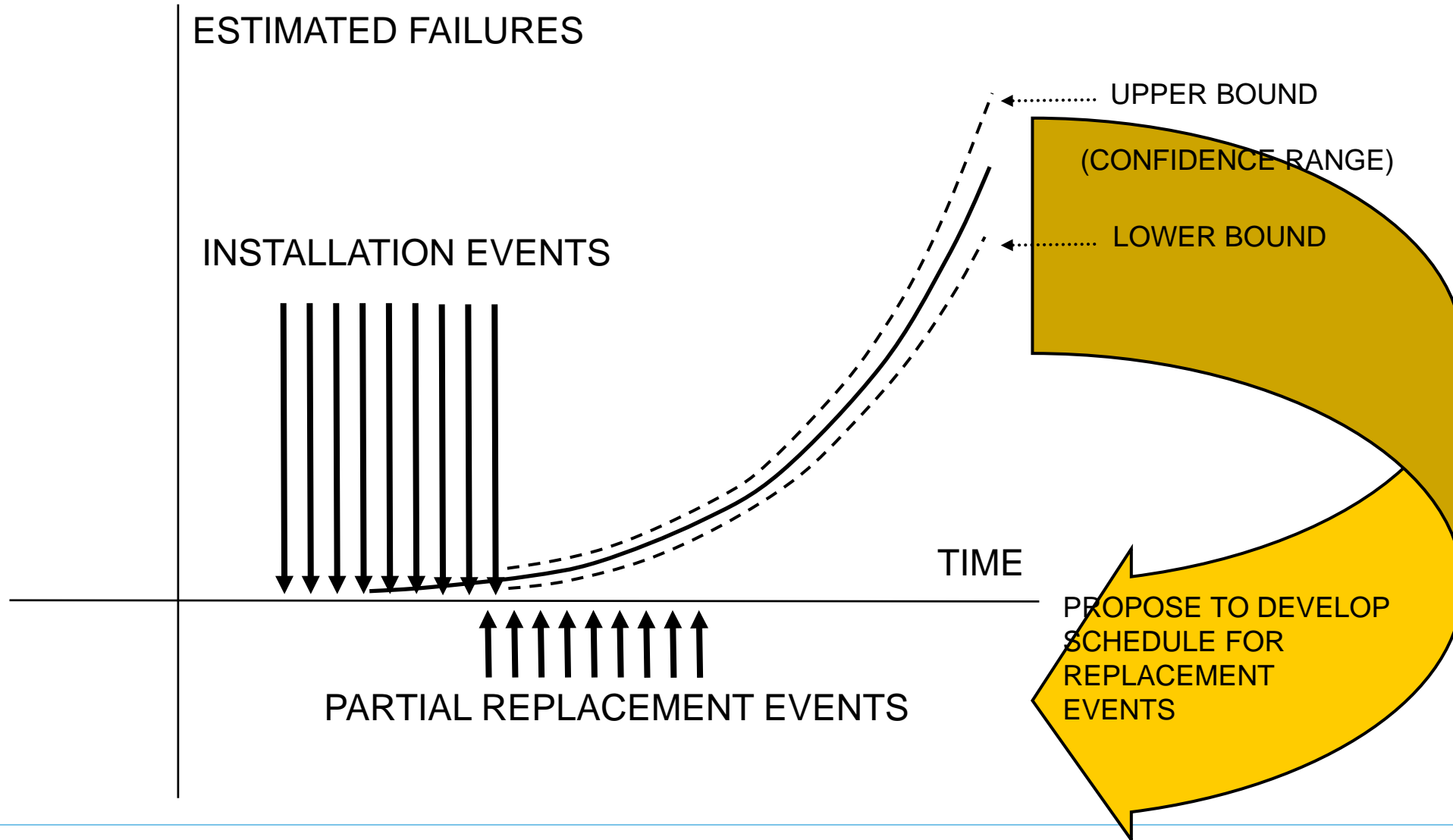

Solution

- **Using Procedure established in Remaining Life II Project**, determine the optimization scenarios to relate the number of estimated failures in the future with the replacement/investment strategies.
- Work with members and appropriate statistician(s) to develop the optimization procedure, then test it on a number of appropriately chosen test cases.
- Incorporate the optimization procedure into the previously developed software for estimation of number of failures.
- Select a system component other than cable to determine how well the established approach works for discrete system components (as opposed to cable which is not discrete)

Progress: Formulation of the Failure Model

- Original Formulation (Forrest):

$$f(t) = X \cdot a \cdot (t - g)^b$$

- Linear Dependence of the Number of Failures on the Length of Installed Cables
- For Multiple Populations:

$$F(t, a, g, b) = \sum_{i=0}^k f_i(t) = \sum_{i=0}^k X_i \cdot a \cdot (t - g - i)^b$$

Revised Failure Model

- Time to 1st failure is a random variable as per previous slide
- Time to Nth failure is a sequence of random variables (renewal process)
- Revised failure model is not linearly dependent on the length of the installed cable:

$$F(t, a, g, b, K) = \sum_{i=0}^k f_i(t) = \sum_{i=0}^k X_i^{1/a} \cdot K \cdot (t - g - i)^b$$

Algorithm Checking with Test Data

Table 1. Results with optimal coefficients

g	a_opt	b_opt	c_opt	norm
1	0.0136	1.1382	1.6823	55.79
2	0.0183	1.1367	1.8369	55.63
3	0.0133	1.1411	1.6738	55.80
4	0.0124	1.1551	1.6579	55.86
5	0.0116	1.1421	1.6104	55.88
6	0.0109	1.1475	1.5921	55.91

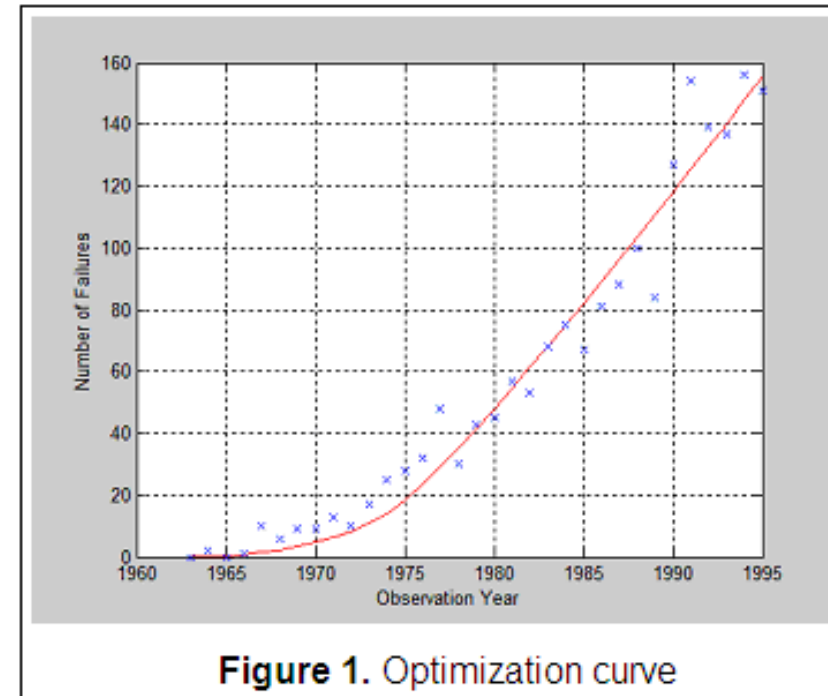

Accounting for Replacement Cables

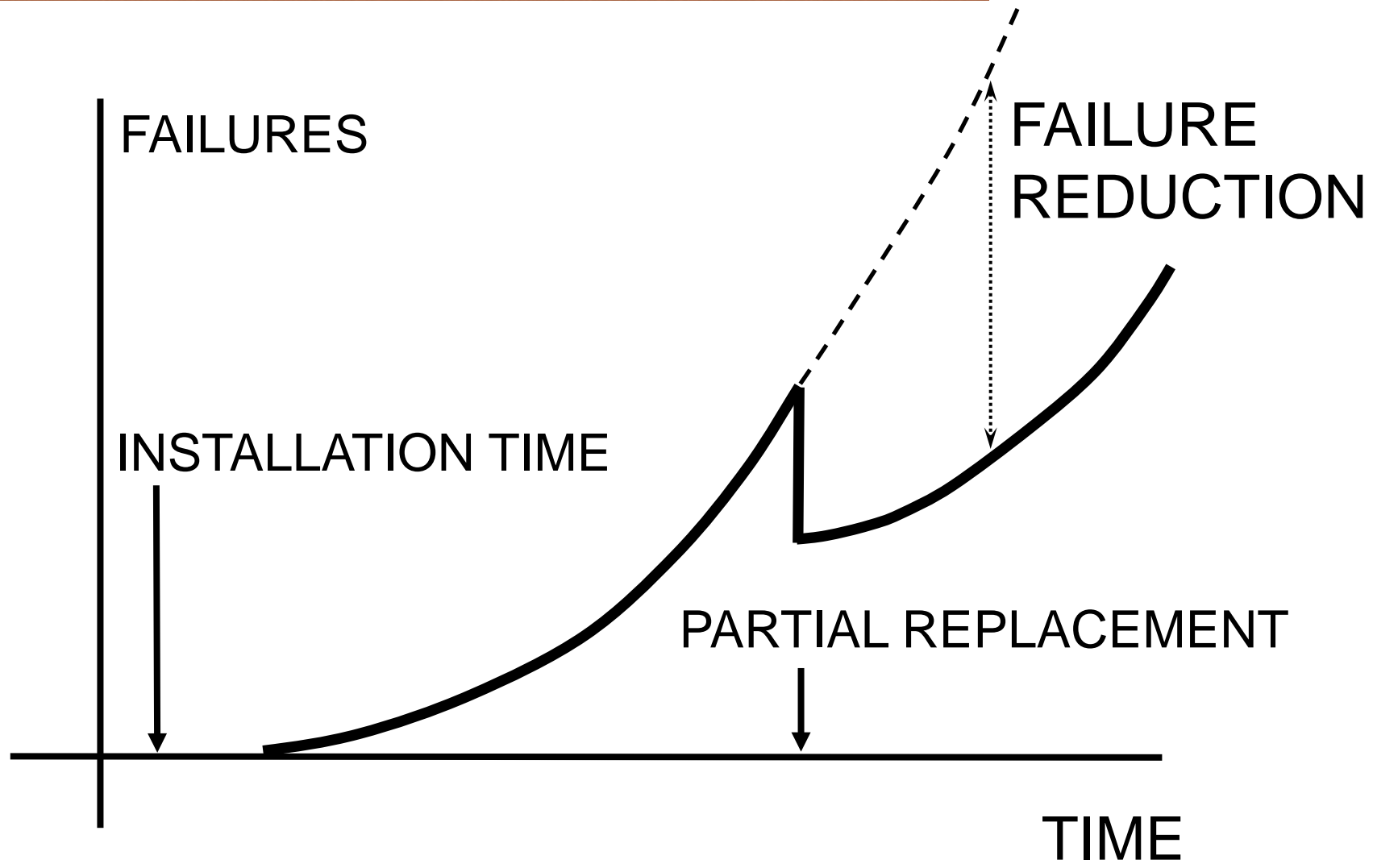

Procedure for Planning Purposes

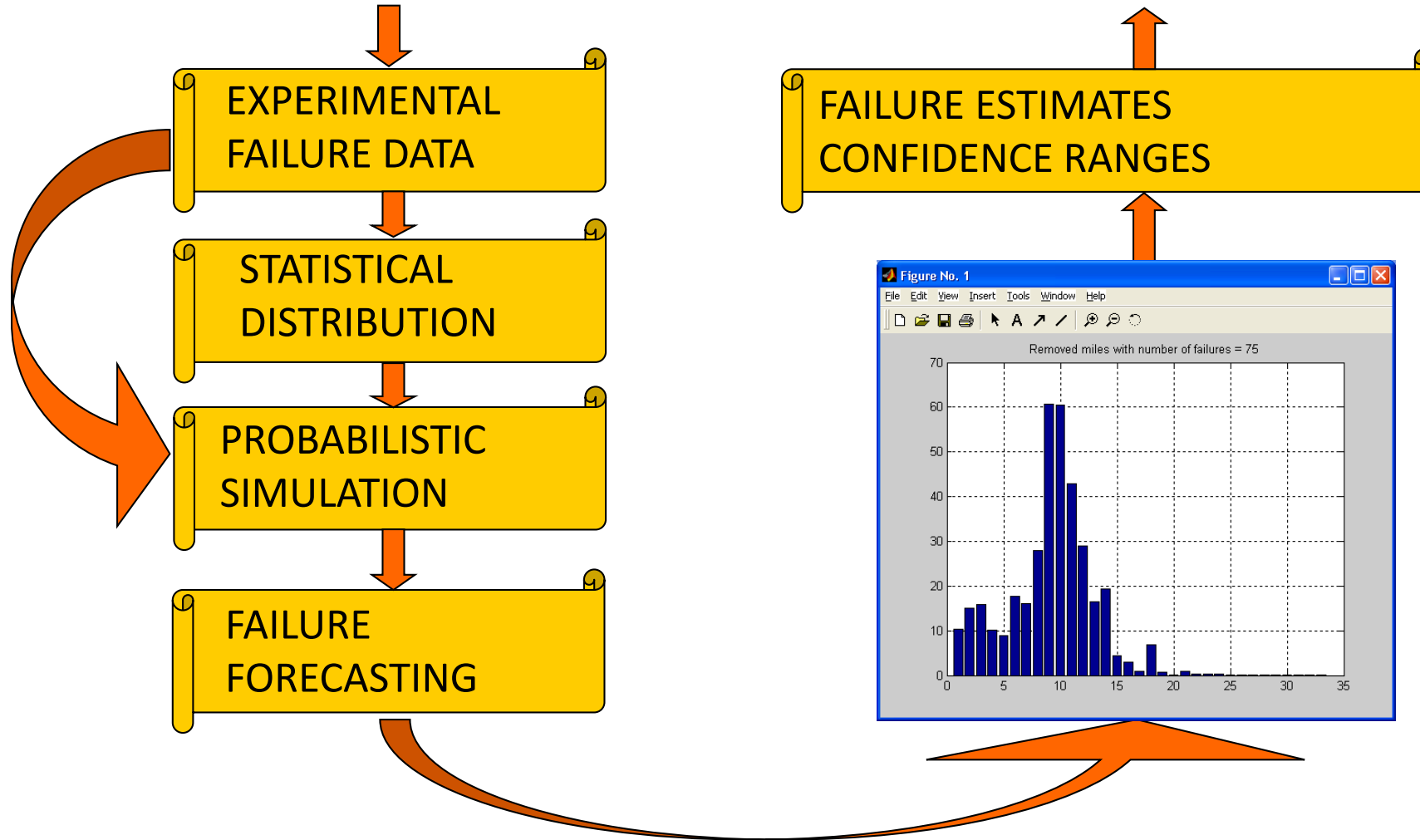

EV Integration Impact on Distribution System Resilience and Operation

Electric Vehicle (EV) Grid Integration

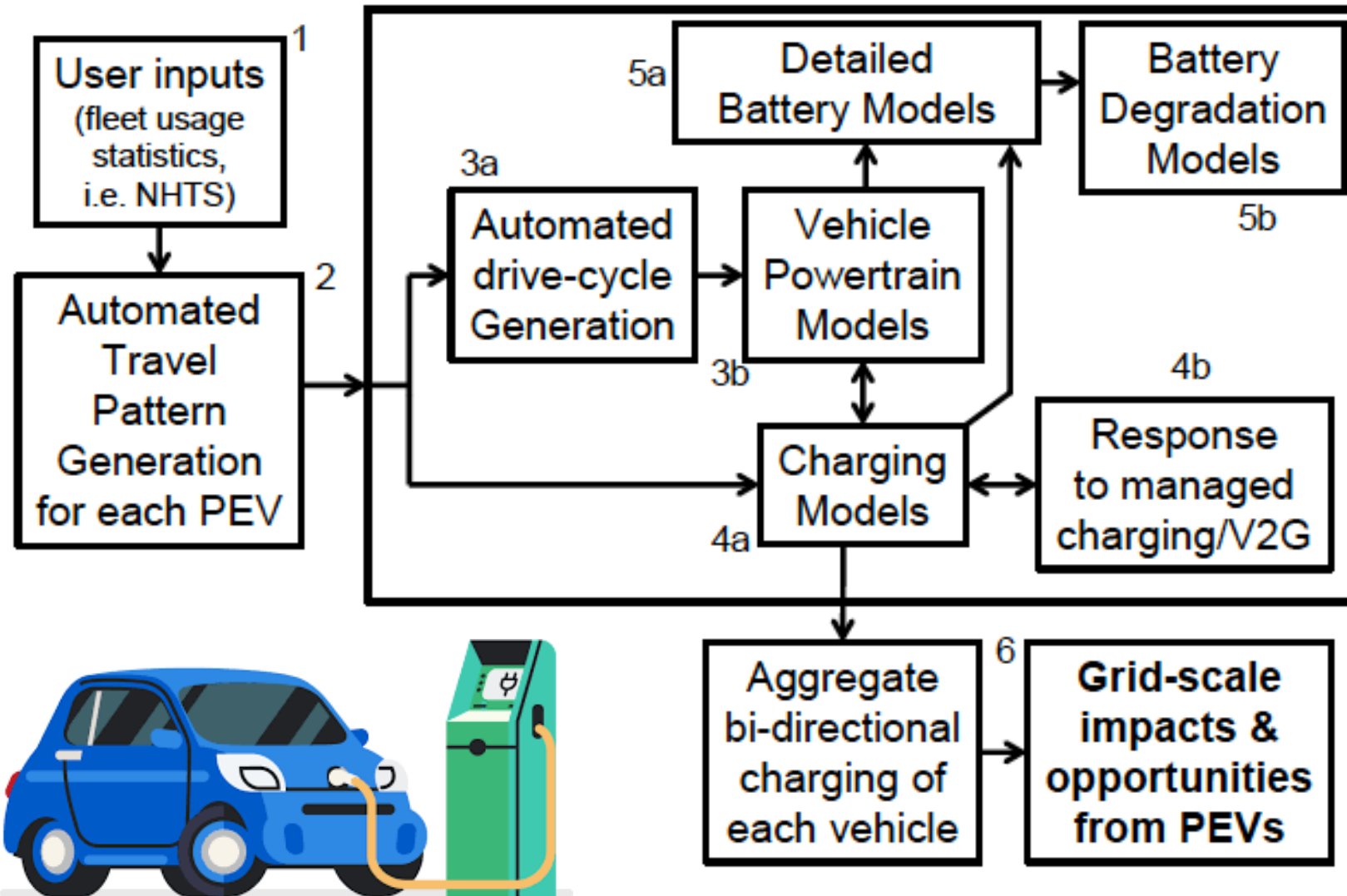

Distribution Load Impact of

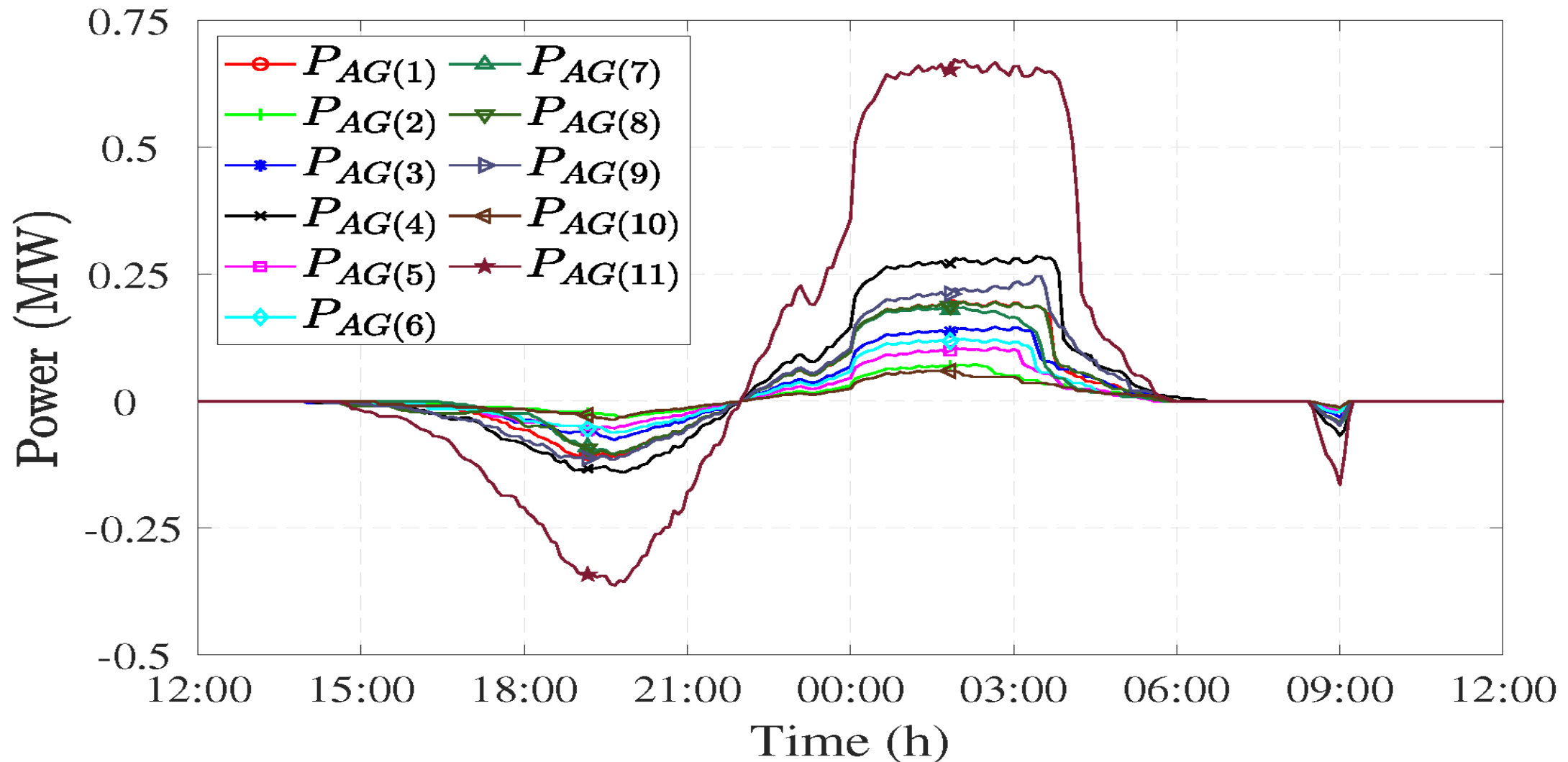

Adaptive EV Load

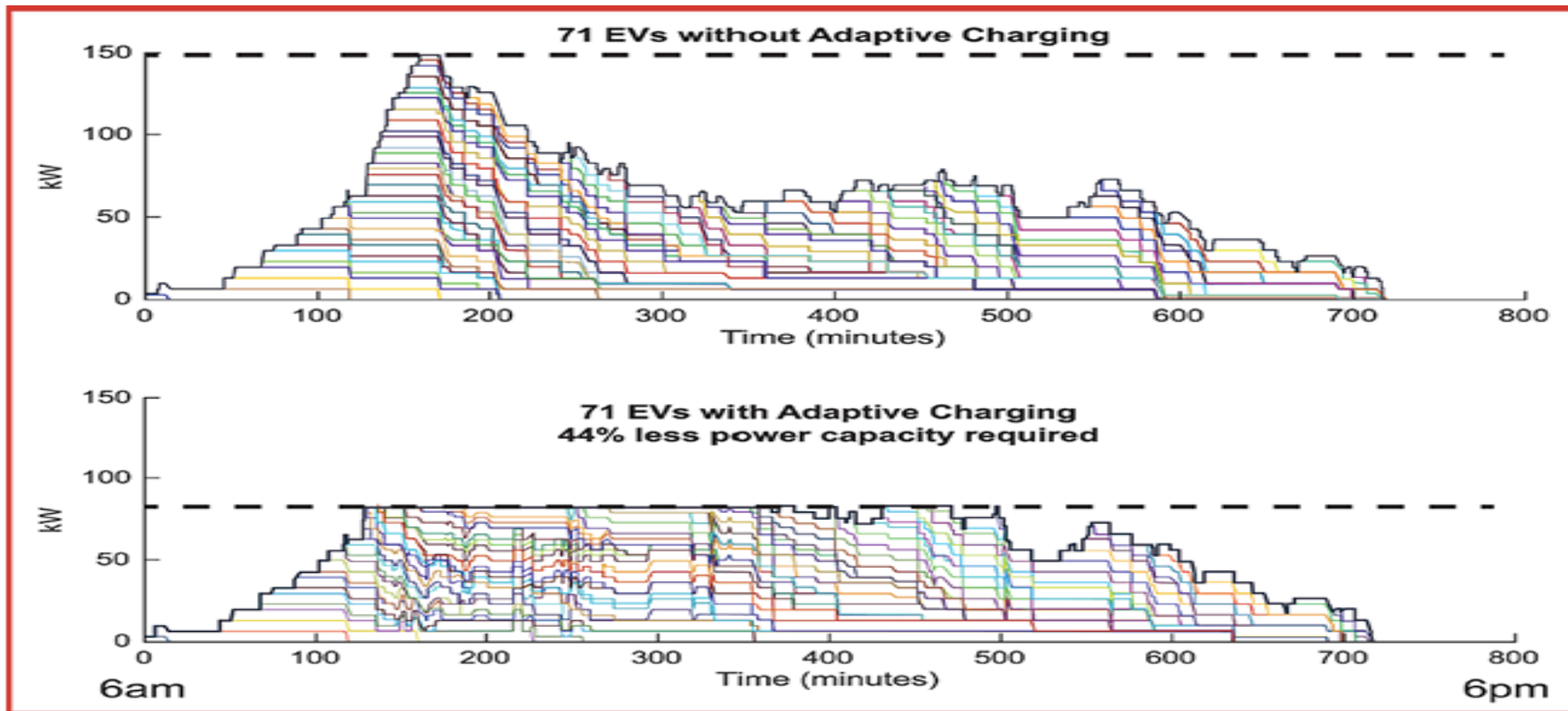

Peak Loads and Distribution Transformer

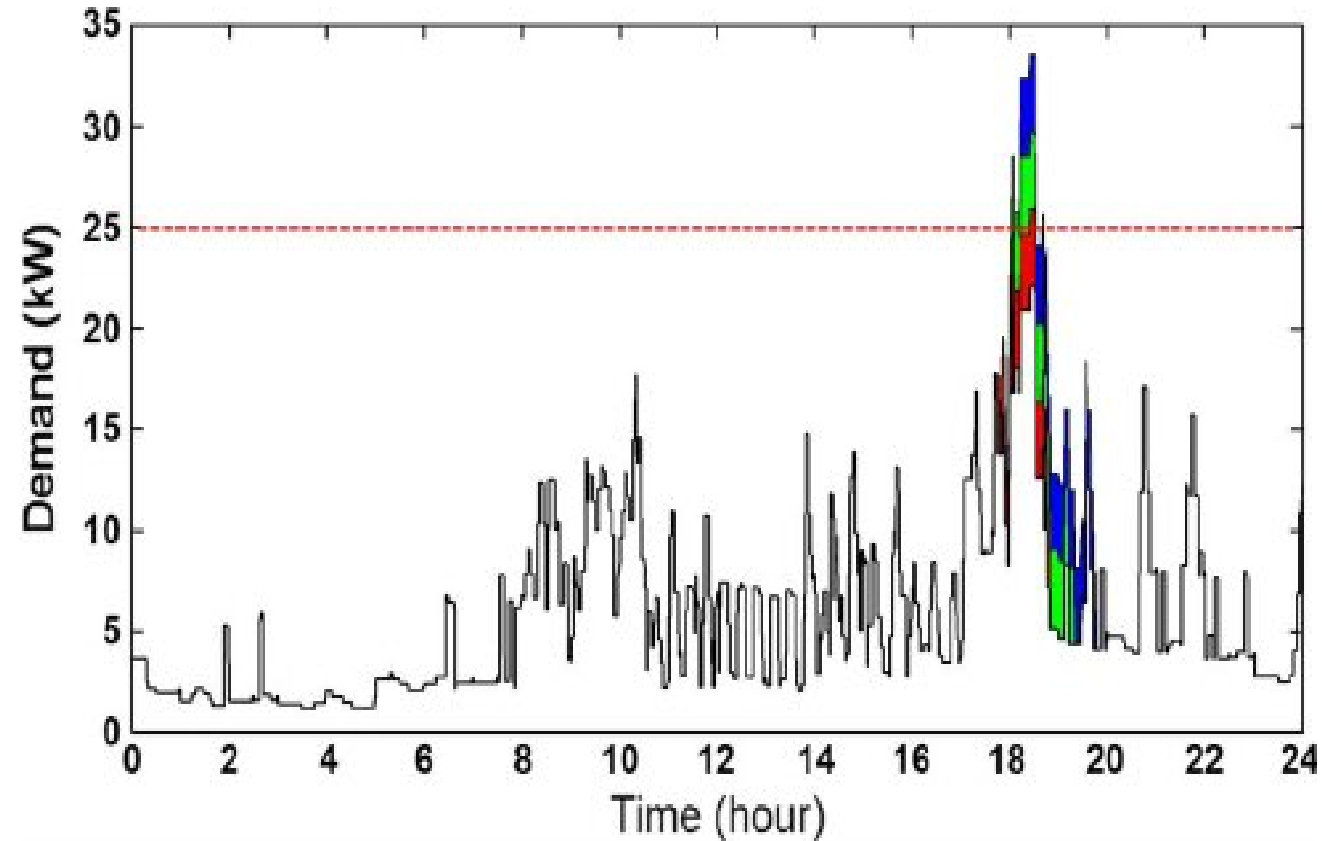
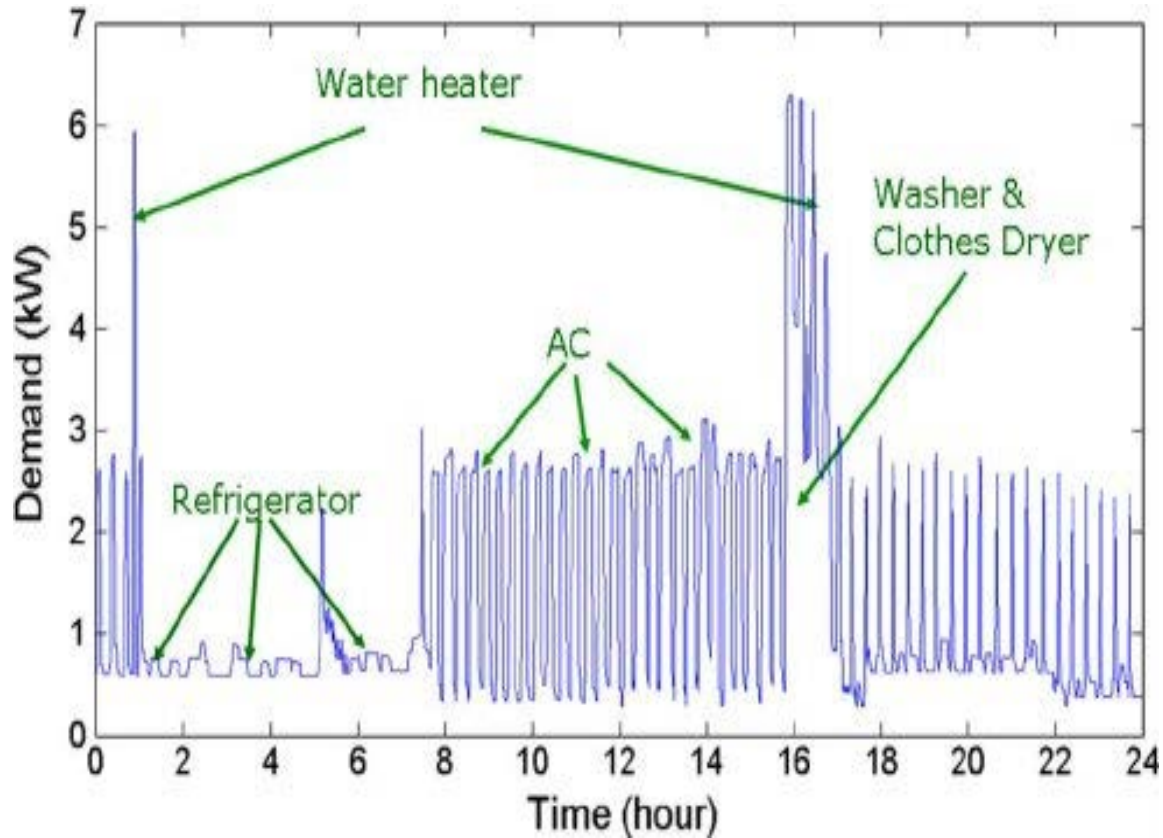

EV Fast Charging

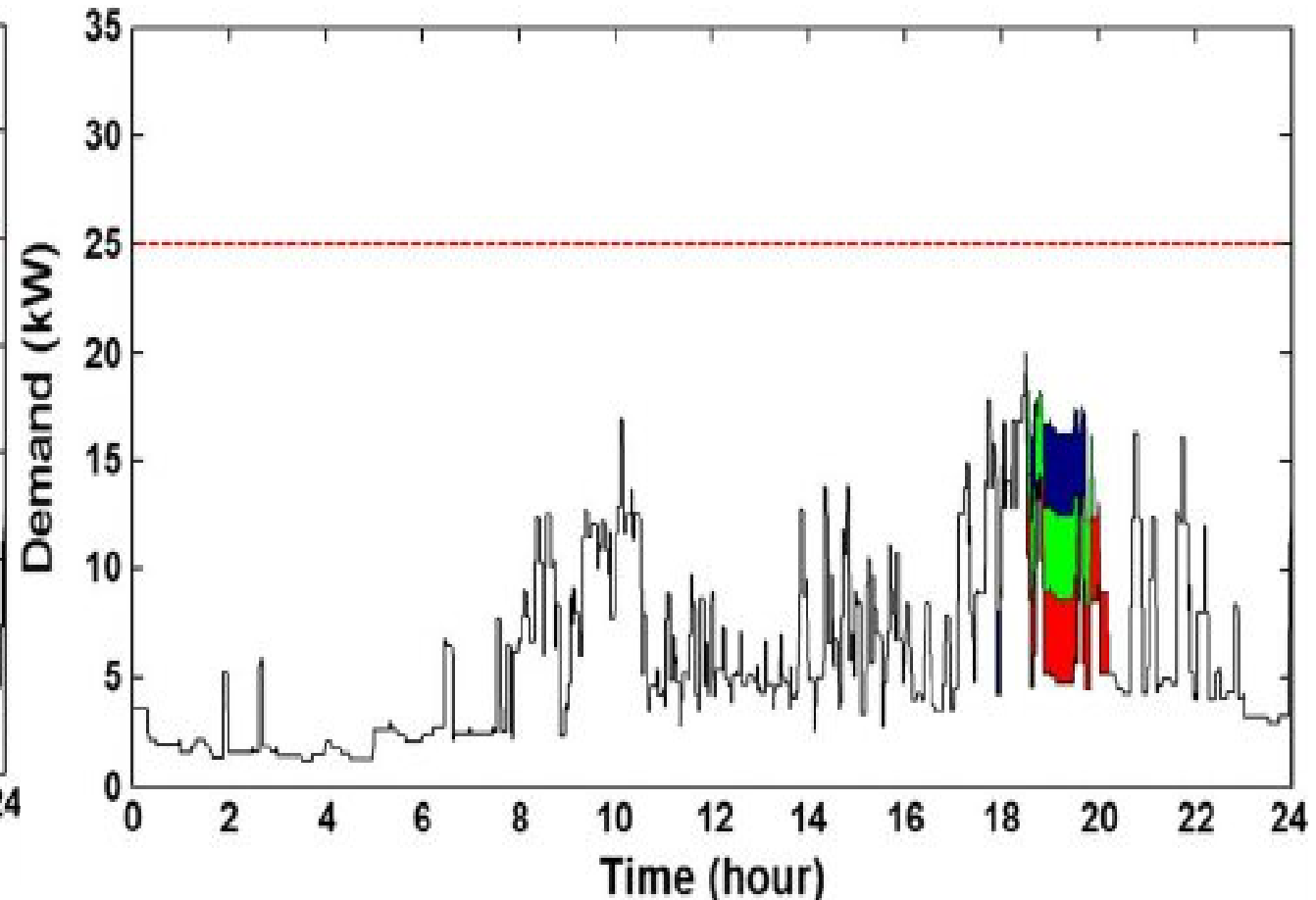
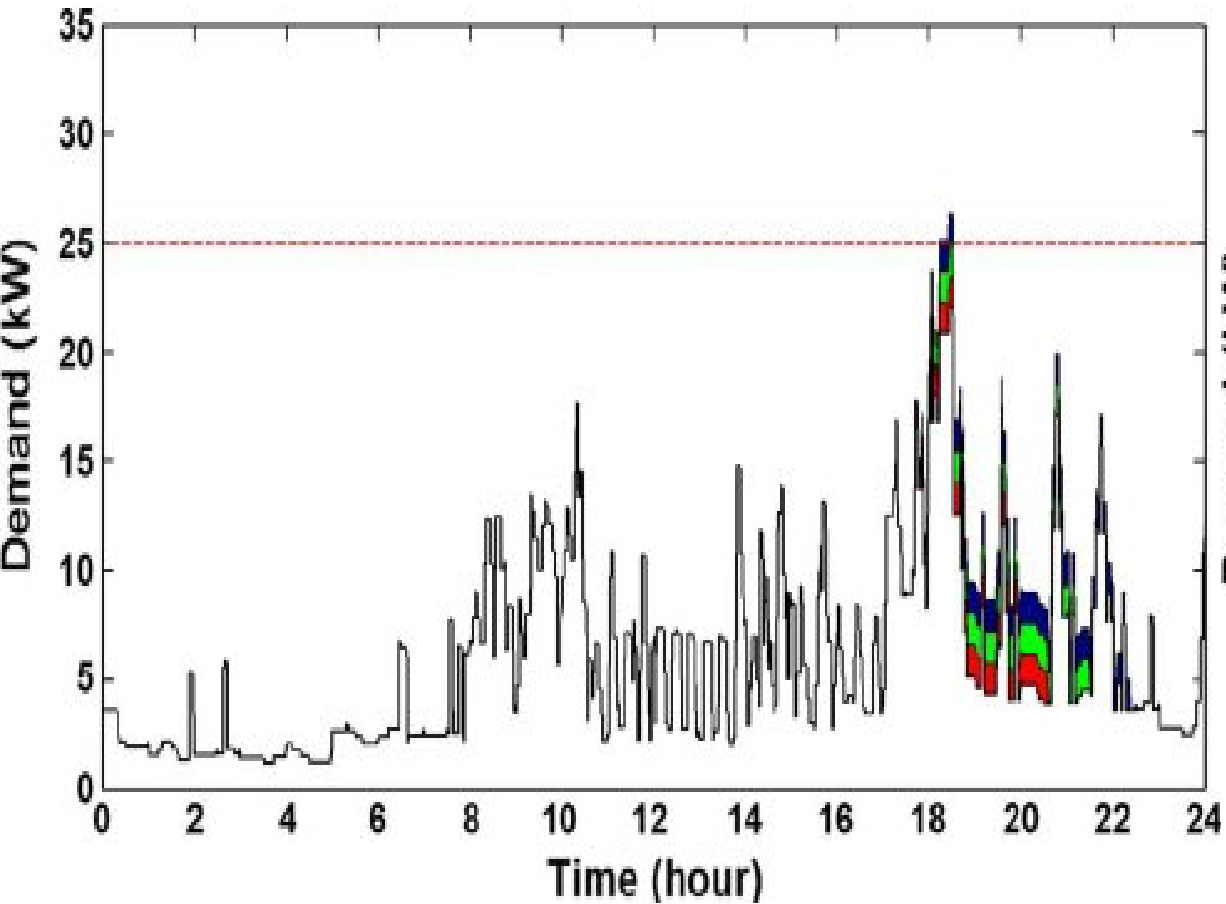

Recommendations

- Overload Management of Distribution Transformer (DT)
- BESS interconnection Downstream from DT
- Optimizing the Life of Distribution Transformer
- Define Variable Shave Level Based on Overload Duration and Temperature
- Real-Time Measurement of Loss of Life of DT and BESS
- BESS Sizing Needed to Optimally Meet the Peak Demand
- Cost Benefit Analysis

Thank You ◀

Feedback and
Interest Survey ◀



Dr. Miroslav M. Begovic, FIEEE

Email: begovic@tamu.edu

